

Automation for a Changing World

Delta Linear Motion Products



www.deltaww.com





 **DELTA**
Smarter. Greener. Together.



Delta Linear Motion Product Introduction

Delta has been dedicated to the motion control field for two decades. With robust experience and in-depth insight into the industry, Delta has launched its linear motion products with advantages that fulfill the hardware requirements of high-end technological applications. Delta linear motion products feature high speed, high precision, high efficiency, and stability. The products include linear motors, ball screw driven linear stages, linear modules, and linear encoders.

Delta's linear motion products help customers develop technologies in different fields and fulfill applications in the electronics, precision finishing, and semiconductor industries. In addition, the products also help increase productivity per direct labor and accelerate equipment development time.

Besides the hardware of the linear motion products, Delta also builds comprehensive motion control solutions with its servo drives and host controllers based on different requirements and has achieved success in numerous applications. Looking forward, Delta will leverage its extensive experiences and join forces with customers by providing outstanding motion control solutions to enhance industrial momentum and embrace the future of "Digitized Automation for a Changing World".

Linear Motors and Linear Encoders			
ECML-S	ECM-PU	ECM-PF	MSR-LEH
Coreless Linear Shaft Motor	Coreless U-shape Linear Motor	Flat Iron Core Linear Motor	Optical Linear Encoder
			

Linear Modules		
LPL	LA-S	LU
Linear Pocket Actuator	Linear Motor Driven Linear Stage	Ball Screw Driven Linear Stage
		

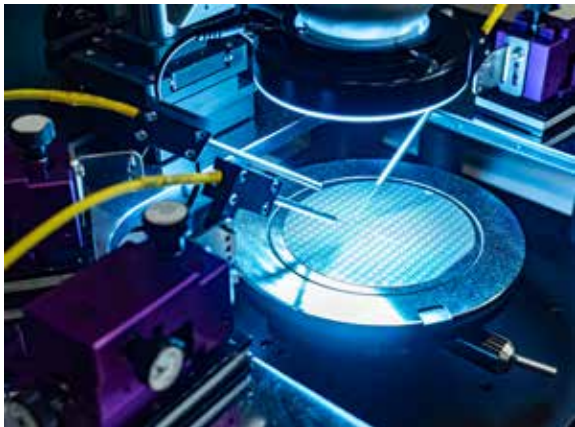

Contents

Linear Motion Products Introduction	1
Linear Motors	3
Products Overview	
Coreless Linear Shaft Motor ECML-S Series	
Coreless U-shaped Linear Motor ECM-PU Series	
Flat Iron Core Linear Motor ECM-PF Series	
Wiring and Extension Cable Specifications	
Linear Modules	31
Linear Motor Driven Mini Actuator LPL	
Linear Motor Driven Linear Stage LA-S Series	
Ball Screw Driven Linear Stage LU Series	
Optical Linear Encoders	52
Delta Servo Drives Introduction	56
Product Selection Table	58



Linear Motors

Product Overview

Coreless Linear Shaft Motor ECML-S



- ▶ Continuous Thrust 22~353N
- ▶ Peak Thrust 87~1,380N

Suitable for semiconductors and electronics assembly



U-shaped Coreless Linear Motor ECM-PU

- ▶ Continuous Thrust 13~377N
- ▶ Peak Thrust 65~2,420N

Suitable for semiconductors and electronics assembly



Flat Iron Core Linear Motor ECML-PF



- ▶ Continuous Thrust 125~1,000N
- ▶ Peak Thrust 377~2,862N

Suitable for semiconductors and electronics assembly



Features

Linear Motor System has the following advantages compared to the system of rotary motor and screws

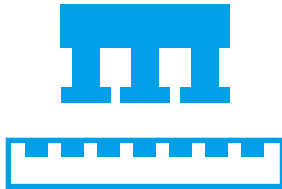

Non-contact design without friction and attrition

- ▶ No contact between rotors and stators and no backlash
- ▶ Increases lifetime and reduces maintenance costs
- ▶ A simple system without the need for coupling and screws
- ▶ Easy installation, big gap between rotors and stators
- ▶ Direct drive structure, fast response time, and high speed
- ▶ Smooth running without dust and noise

High motion speed and high acceleration /deceleration

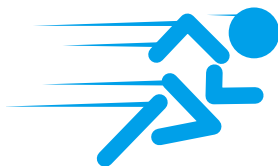

- ▶ Non-contact direct-drive design, faster speed, acceleration, and deceleration
- ▶ Speed of the linear motor can reach 4m/s and even more^{*1}
- ▶ Acceleration of the linear motor can reach 5G ~ 10G and even more^{*2}

* Notes 1 & 2: The actual performance may vary due to the environment, application types, or scenarios

High resolution, high positioning precision, and high repeatability



- ▶ Employs encoders for position feedback
- ▶ High resolution linear encoders fully cover levels of μm to nm
- ▶ Outstanding precision with linear encoders
- ▶ Delta also offers linear encoders; Refer to page 52 for more details

Shaft-type multi-rotor applications for space and efficiency enhancement

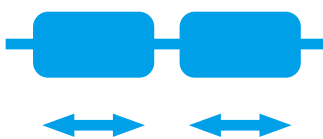

- ▶ Supports multiple rotors on a single shaft
- ▶ Rotors work individually
- ▶ Space utility increases by the number of stators
- ▶ Multi-stator application for space-saving and efficiency enhancement

Principles and structures of linear motors

Direct drive, simple system and suitable for a wide range of applications

- Linear motors can be thought of as rotary motors that have been cut along a radial plane and unrolled

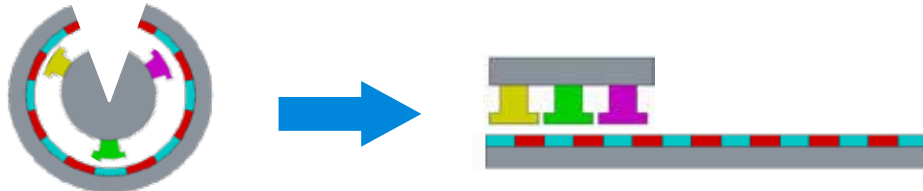

- Simple structure without a redundant switching mechanism to avoid impacts with speed, precision, and response

Rotary Motor System

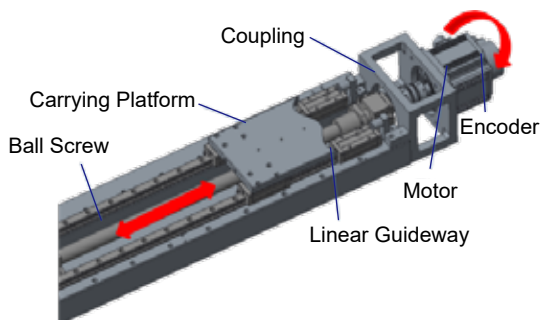

Linear Motor System

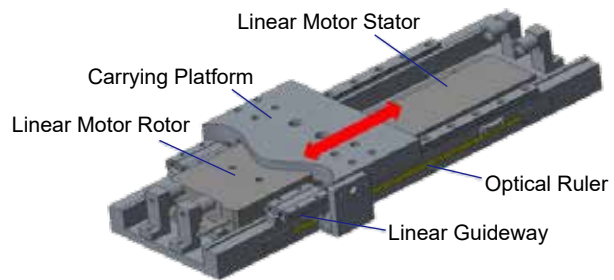

- Comparison between different types of linear motors

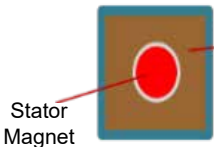
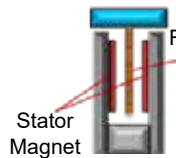
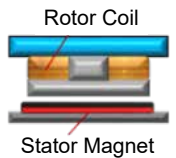
Comparison	Linear Shaft Motor	U-shape Linear Motor	Flat Core Linear Motor
Structure			
Air Gap	O	O	O
Iron Core	X	X	O
Cogging Force	X	X	O
Magnetic Attraction Effect	X	X	O
Travel	Short	Theoretically Unlimited	Theoretically Unlimited
Heat Release	Best	Normal	Second Best
Thrust	Mid-small	Mid-small	Large
Application	Continuity	Continuity	Point-to-point

Coreless Linear Shaft Motor ECML-S Series



Stable speed

Shaft-type structure with excellent speed stability and low ripple effect; Suitable for applications that require high precision in unit time



Multiple Rotors Simultaneous Movement

The single-shaft stator with fixed travel supports multiple rotors to move individually for space utilization and production efficiency enhancement



Ultra-high Efficiency

Operation releases the heat of rotors for high efficiency; Suitable for applications that require high sensitivity to temperature



Continuous-path Movement

Coreless structure without cogging forces; Suitable for applications that require smooth continuous movements, such as electronics assembly, semiconductors, and optical inspections

Product Introduction

Delta's shaft-type linear motor is designed with a coreless structure that features excellent capabilities for heat release, high efficiency, high dynamic response, low speed ripple without cogging force, abrasion and backlash. The rated thrust is from 22 to 353 N, which is suitable for applications with continuous-path movement demands, such as electronic components and assembly, semiconductors, and optical inspections. The structure is similar to the screw system and easy to replace.

Product Advantages

- ▶ Built-in hall and temperature sensors for all models in the series, no need for extra installation
- ▶ Special design to reduce temperature rise; Avoids changes of temperature that affect equipment precision
- ▶ Executive magnetic design to optimize unit thrust (with Delta Servo Drive)
- ▶ Builds complete motion control solution* with controllers, drives, and linear encoders

* Notes:

- For the specifications of the controllers, please refer to Delta's official website
- For the specifications of the servo drives, please refer to page 55
- For the specifications of linear encoders, please refer to page 52

Ordering Information

Coil assembly

ECML-S 1606 A2 D Q S

Code	Product
ECML-S	Coreless linear shaft motor

Code	Magnetic Way Diameter, Coil
1606	Ø16, 6 coil
1608	Ø16, 8 coil
2003	Ø20, 3 coil
2004	Ø20, 4 coil
2005	Ø20, 5 coil
2504	Ø25, 4 coil
2506	Ø25, 6 coil
2508	Ø25, 8 coil
3204	Ø32, 4 coil
3206	Ø32, 6 coil
3208	Ø32, 8 coil
3505	Ø35, 5 coil
3506	Ø35, 6 coil

Code	Voltage
A2	220V

Code	Type
S	Standard product

Code	Wiring
Q	0.5m Fast switch

Code	Sensors
D	Includes Hall and temperature sensors

Magnetic way

ECML-S M 16 0250

Code	Product
ECML-S	Coreless linear shaft motor

Code	Type
M	Magnetic way

Code	Magnetic Way Diameter
16	Ø16
20	Ø20
25	Ø25
32	Ø32
35	Ø35

Code	Magnetic Way Length
XXXX Examples: 0450 = 450 mm 1000 = 1,000 mm 2790 = 2,790 mm	Magnetic Way Diameter Ø16 250 ~ 1,240 mm · 30 mm per pitch
	Magnetic Way Diameter Ø20 250 ~ 1,270 mm · 60 mm per pitch
	Magnetic Way Diameter Ø25 330 ~ 1,650 mm · 60 mm per pitch
	Magnetic Way Diameter Ø32 450 ~ 2,790 mm · 60mm per pitch
	Magnetic Way Diameter Ø35 810 ~ 2,790 mm · 60 mm per pitch

Thrust Range

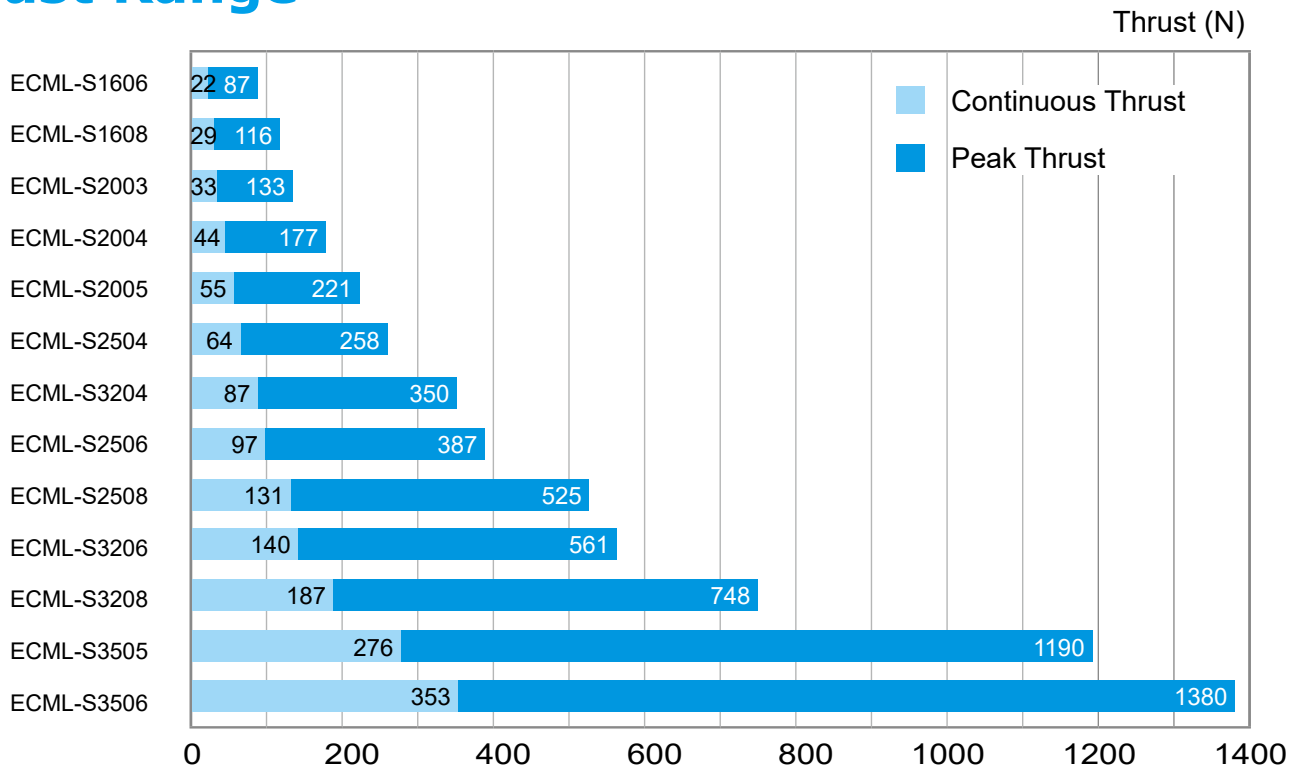

Product Specifications

Electrical specifications

ECML-S	1606	1608	2003	2004	2005	2504	2506	2508	3204	3206	3208	3505	3506	
Rated Thrust (N)	22	29	33	44	55	64	97	131	87	140	187	276	353	
Peak Thrust (N)	87	116	133	177	221	258	387	525	350	561	748	1190	1380	
Rated Current (Arms)	0.66	0.66	1.1	1.1	1.1	1.7	1.7	2.5	1.9	2.7	2.7	2.8	5.6	
Peak Current (Arms)	2.64	2.64	4.4	4.4	4.4	6.8	6.8	10.0	7.6	10.8	10.8	11.2	21.9	
Rated Power (W)	47	62.6	46.9	62.3	78	64.9	97.4	152.5	93.4	151	201.8	273.2	321.8	
Peak Power (W)	751.7	1001.3	749.7	997.1	1248.3	1038.6	1557.8	2439.6	1494.1	2416.5	3229.5	4371.9	4921.8	
Thrust Constant (N/Arms)	33.0	44.0	30.2	40.3	50.3	37.9	56.9	52.5	46	51.9	69.3	106.2	63	
BEMF Constant ($V^{pk}/m/s$)	27.0	36.0	24.7	32.8	41.2	30.9	46.6	42.9	37.5	42.4	56.6	86.7	51.5	
Motor Constant (N/ \sqrt{W})	3.20	3.70	5.50	6.40	7.10	8.0	9.8	10.6	8.8	11.3	13	18	19.7	
Armature Resistance (Ohm, L-L)	55.7	74.2	15.5	21.6	25.9	11.6	17.4	12.6	13.36	10.7	14.3	18	5.3	
Armature Inductance (mH, L-L)	10.5	14	7	9	11	14.6	22	23	16	12.5	16.6	38.32	11.5	
Electric Constant (ms)	0.19	0.19	0.35	0.34	0.33	1.26	1.26	1.83	1.2	1.17	1.16	2.13	2.18	
Weight of Coil Assembly (kg)	0.35	0.5	0.7	0.8	1.0	1.1	1.6	2.1	1.5	2.2	2.8	3.2	3.9	
Weight of Magnetic Way (kg/m)	1.5		2.4			3.7			6.0			7.0		
Magnetic Pole Pitch (mm)	30		60			60			60			120		
Air Gap (mm)	0.75						1			1.75			3	
Vertical Attraction Force (N)	0													
Allowable Winding Temp. (°C)	120													
Insulation Resistance	>10 MΩ · 500 V _{DC}													
Withstand Voltage	1,500 V _{AC} · 60 sec													
Operating Ambient Temp. (°C)	0 ~ +40													
Storage Temp. (°C)	-10 ~ +80													
Operating Relative Humidity (RH)	20 ~ 80% (Non-condensing)													
Storage Humidity (RH)	20 ~ 80% (Non-condensing)													
Approvals	CE													
Magnetic Way Length (mm)	250 ~ 1,240		250 ~ 1,270			330 ~ 1,650			450 ~ 2,790			810 ~ 2,790		
ASD Servo Drive	A3-0121- □		A3-0221- □			A3-0421- □			A3-0721- □			A3-1021- □		

* Note: Specifications tolerance – inductance ±30%, all others ±10%

Product Specifications

Thrust-speed curves

ECML-S1606

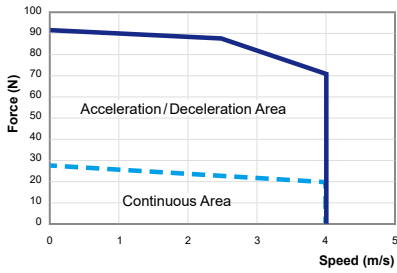

ECML-S1608

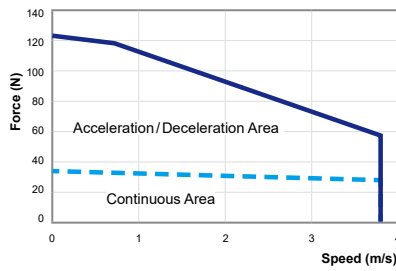

ECML-S2003

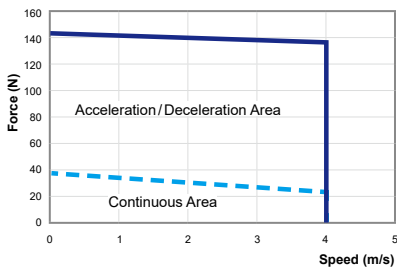

ECML-S2004

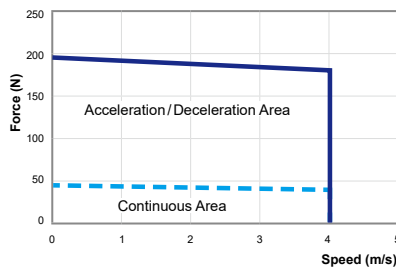

ECML-S2005

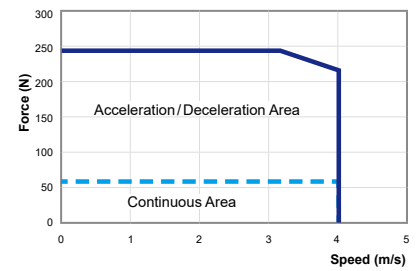

ECML-S2504

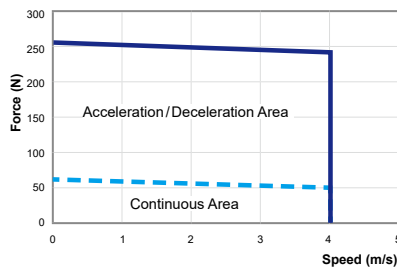

ECML-S2506

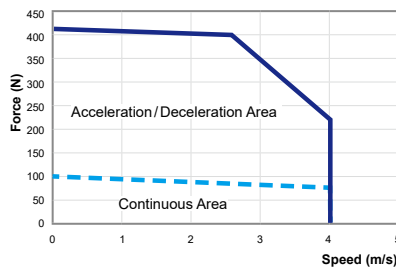

ECML-S2508

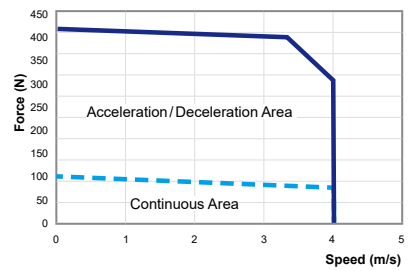

Thrust-speed curves

ECML-S3204

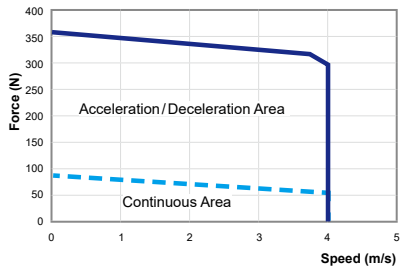

ECML-S3206

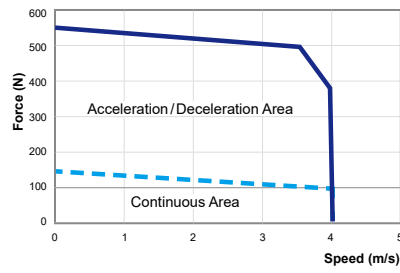

ECML-S3208

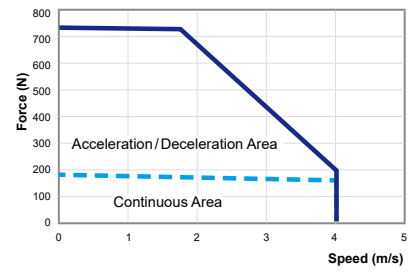

ECML-S3505

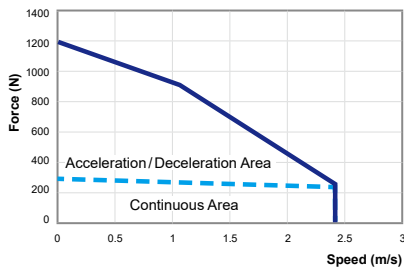

ECML-S3506

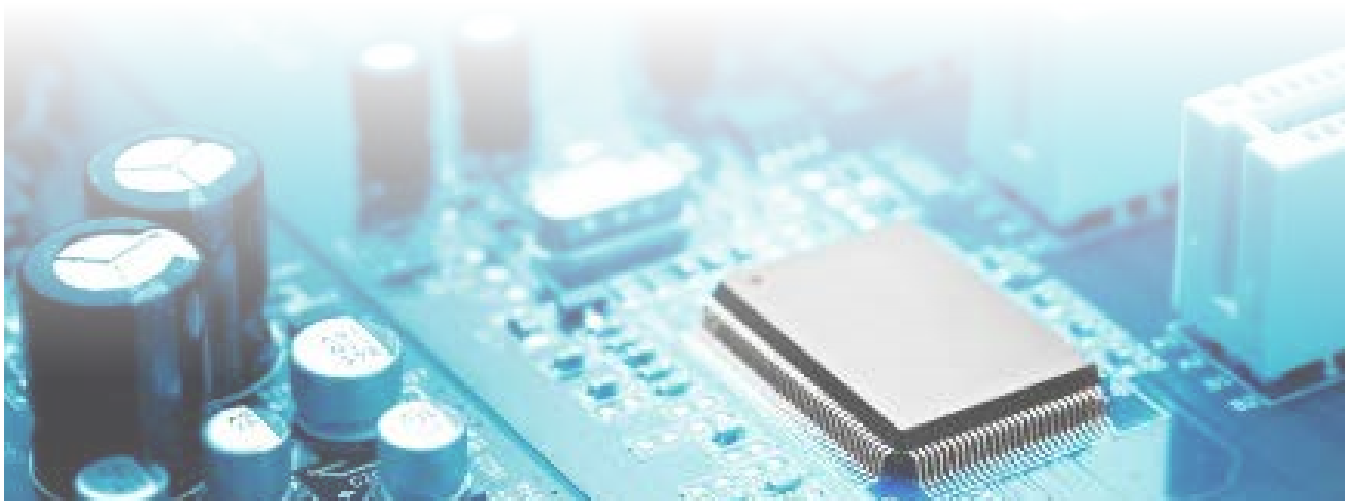
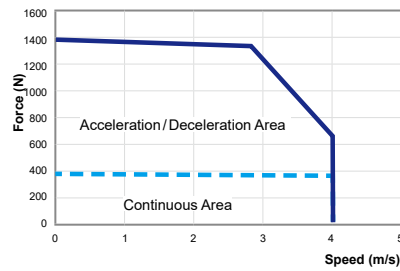

Product Dimensions

Rotor dimensions, ECML-S16 Series

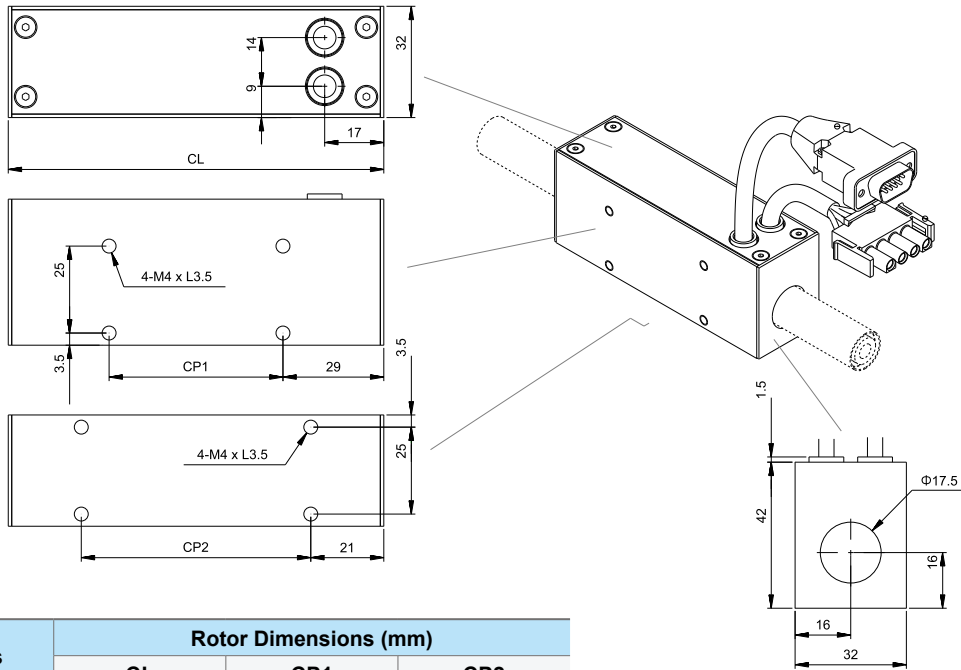

Rotor Models	Rotor Dimensions (mm)		
	CL	CP1	CP2
ECML-S1606A2DQS	108	50	66
ECML-S1608A2DQS	138	80	96

Stator dimensions, ECML-SM16 Series

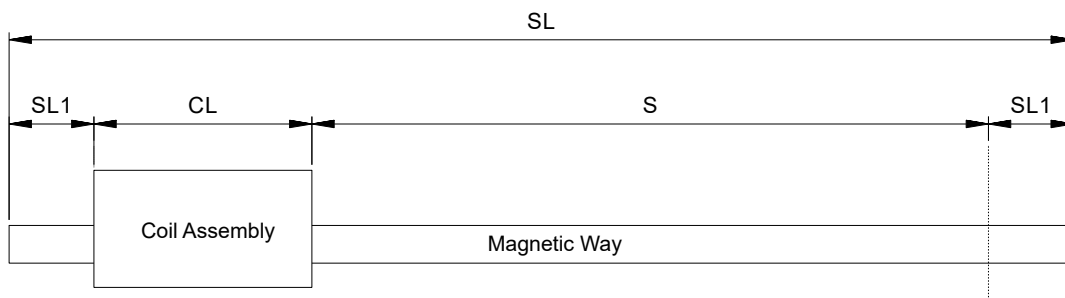

Stator Dimensions (mm)			Weight
Overall Length (SL)	Suggested Clamping Length (SL1)	Effective Stroke (S)	(kg)
250 - 370	35	$S = SL - 2 * SL1 - CL$	1,000 mm = 1.48 kg
400 - 790	40		
820 - 1,240	60		

* Note: The overall length of the stator of the ECML-SM16 Series is SL, and a single pitch is 60mm

Rotor dimensions, ECML-S20 Series

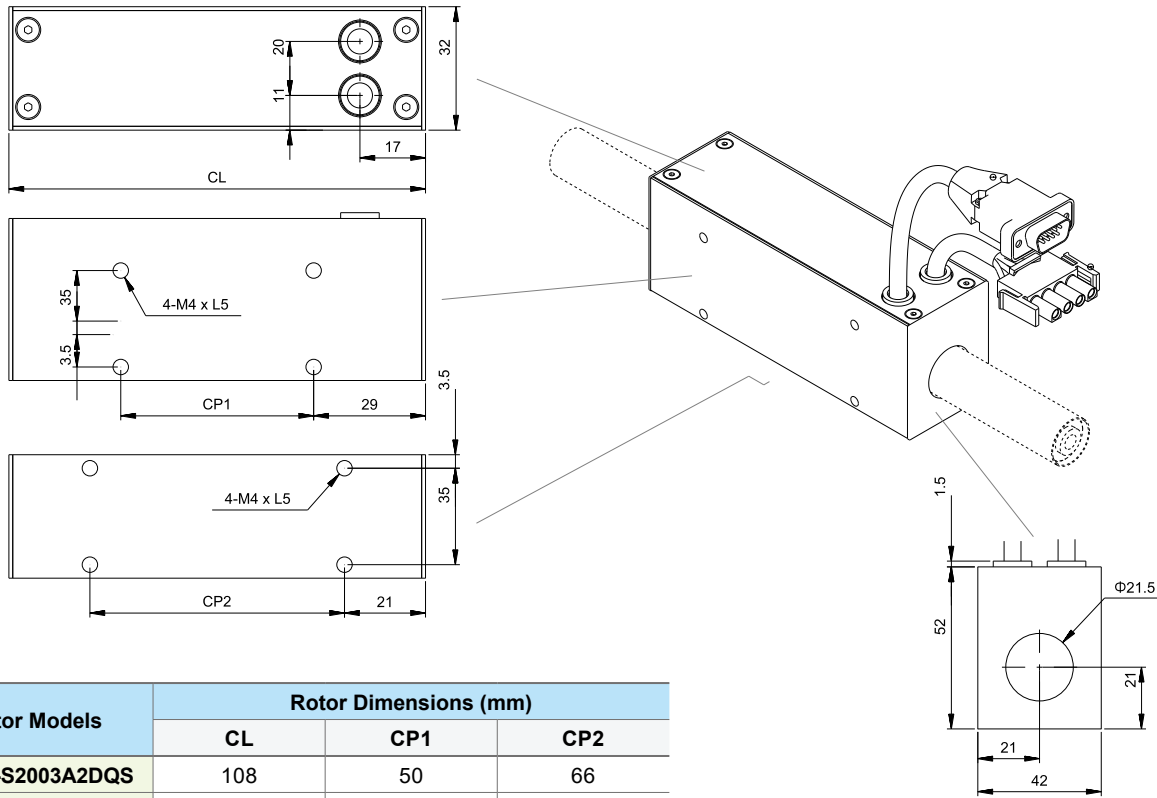

Rotor Models	Rotor Dimensions (mm)		
	CL	CP1	CP2
ECML-S2003A2DQS	108	50	66
ECML-S2004A2DQS	138	80	96
ECML-S2005A2DQS	168	110	126

Stator dimensions, ECML-SM20 Series

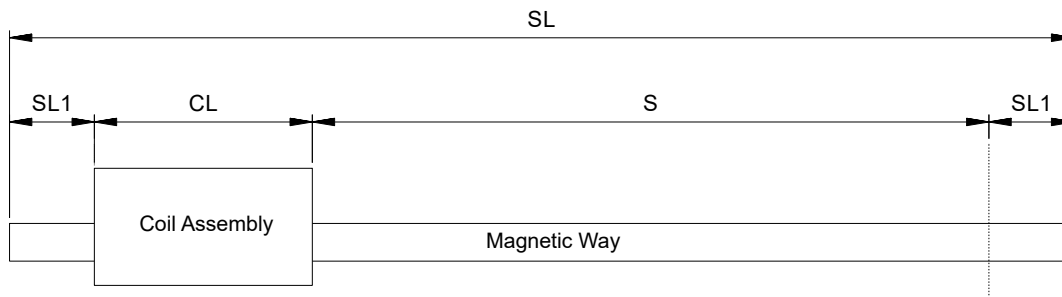

Stator Dimensions (mm)			Weight
Overall Length (SL)	Suggested Clamping Length (SL1)	Effective Stroke (S)	(kg)
250 - 1,270	35	$S = SL - 2 * SL1 - CL$	1,000 mm = 2.36 kg

* Note: The overall length of the stator of the ECML-SM20 Series is SL, and a single pitch is 60mm

Product Dimensions

Rotor dimensions, ECML-S25 Series

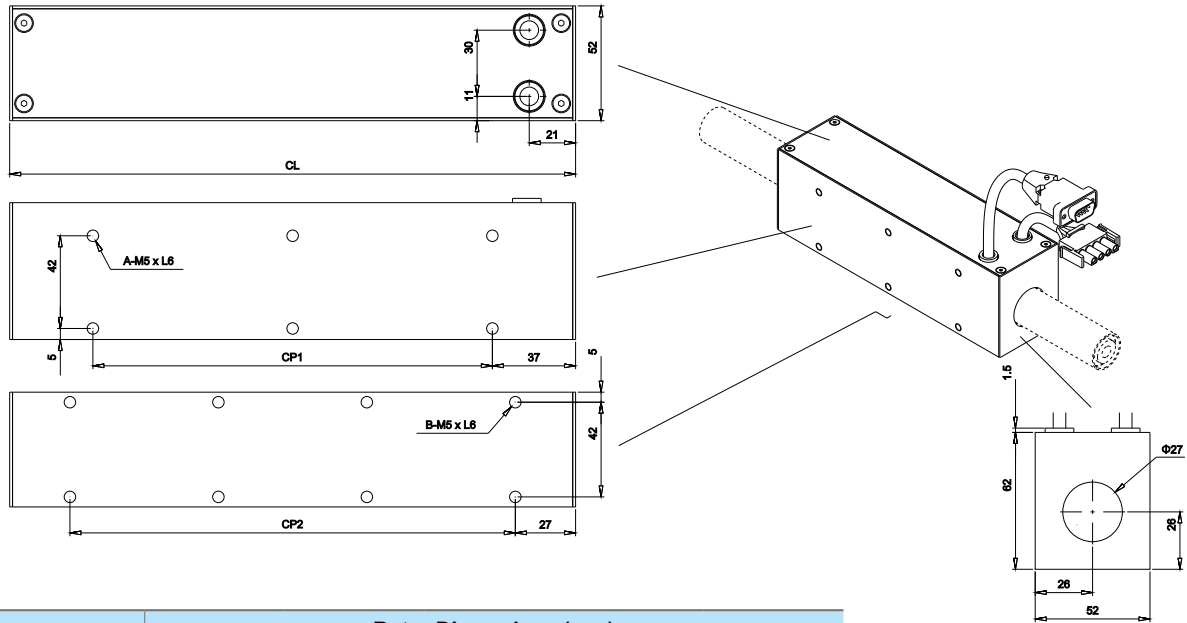

Rotor Models	Rotor Dimensions (mm)				
	CL	CP1	CP2	A	B
ECML-S2504A2DQS	138	64	84	4	4
ECML-S2506A2DQS	198	124	144	4	4
ECML-S2508A2DQS	258	92 x 2	68 x 3	6	8

Stator dimensions, ECML-SM25 Series

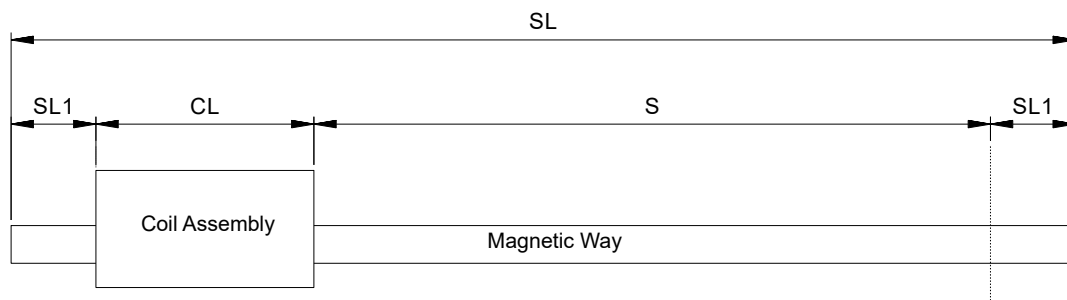

Stator Dimensions (mm)			Weight
Overall Length (SL)	Suggested Clamping Length (SL1)	Effective Stroke (S)	(kg)
330 - 630	45	S = SL - 2*SL1 - CL	1,000 mm = 3.67 kg
690 - 1,290	60		
1,350 - 1,650	70		

* Note: The overall length of the stator of the ECML-SM25 Series is SL, and a single pitch is 60mm

Rotor dimensions, ECML-S32 Series

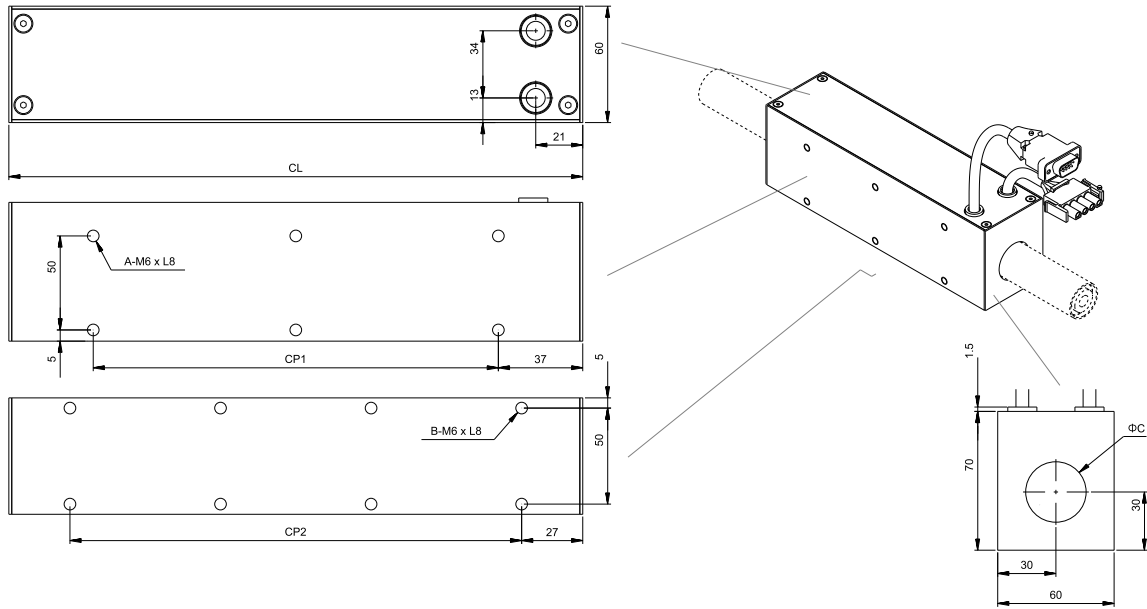

Rotor Models	Rotor Dimensions (mm)					
	CL	CP1	CP2	A	B	C
ECML-S3204A2DQS	138	64	84	4	4	35.5
ECML-S3206A2DQS	198	124	144	4	4	35.5
ECML-S3208A2DQS	258	92 x 2	68 x 3	6	8	35.5
ECML-S3208A2DQA	258	92 x 2	68 x 3	6	8	38

Stator Dimensions, ECML-SM32 Series

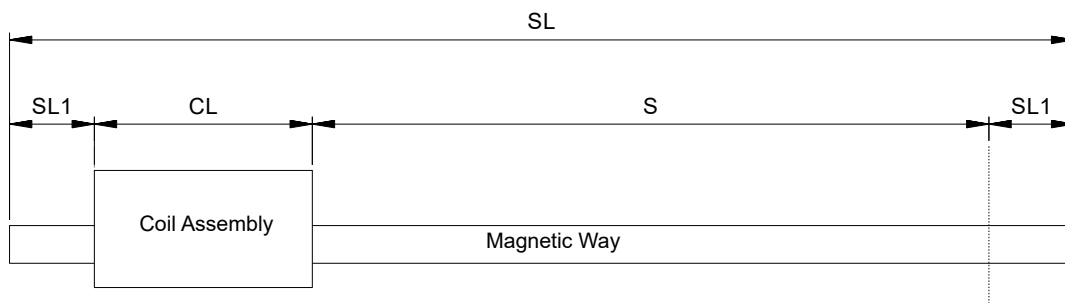

Stator Dimensions (mm)			Weight
Overall Length (SL)	Suggested Clamping Length (SL1)	Effective Stroke (S)	(kg)
450 - 870	60	$S = SL - 2 * SL1 - CL$	1,000 mm = 6 kg
930 - 1,530	90		
1,390 - 2,790	100		

* Note: The overall length of the stator of the ECML-SM32 Series is SL, and a single pitch is 60mm

Product Dimensions

Rotor dimensions, ECML-S35 Series

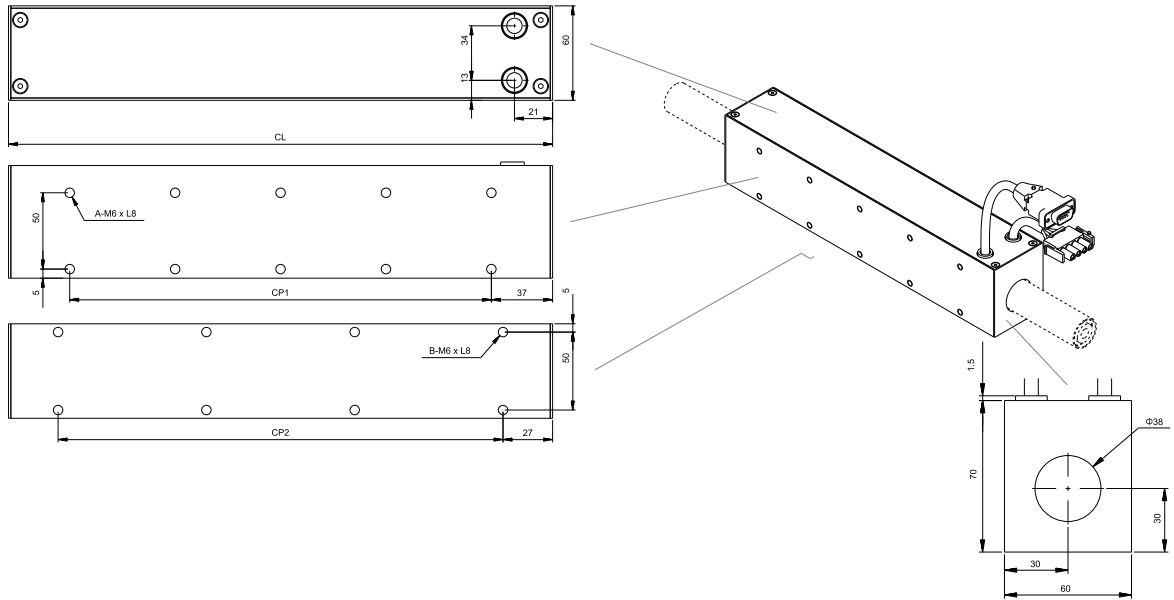

Rotor Models	Rotor Dimensions (mm)				
	CL	CP1	CP2	A	B
ECML-S3505A2DQS	318	122 x 2	88 x 3	6	8
ECML-S3506A2DQS	378	76 x 4	108 x 3	10	8

Stator dimensions, ECML-SM35 Series

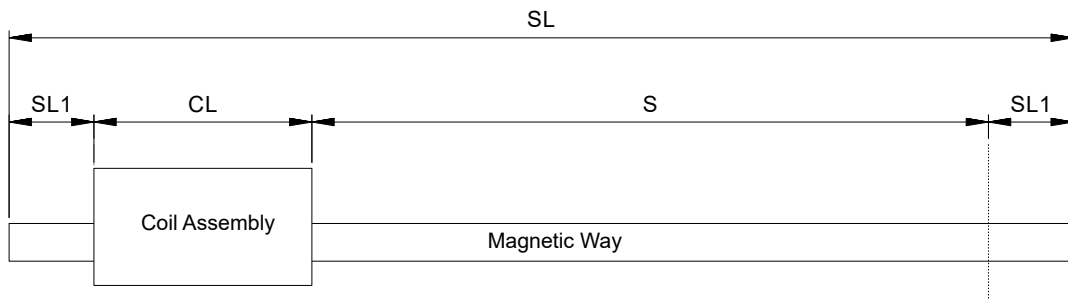

Stator Dimensions (mm)			Weight
Overall Length (SL)	Suggested Clamping Length (SL1)	Effective Stroke (S)	(kg)
810 - 870	60	S = SL - 2*SL1 - CL	1,000 mm = 3.67 kg
930 - 1,470	90		
1,530 - 2,790	100		

* Note: The overall length of the stator of the ECML-SM35 Series is SL, and a single pitch is 60 mm

Coreless U-shape Linear Motor ECM-PU Series



Stable Speed

U-shaped structure with outstanding speed stability and low ripple effect; Suitable for applications that require high precision in unit time



Multiple Rotors Simultaneous Movement

The single-shaft stator with fixed travel supports multiple rotors that move individually for space utilization and production efficiency enhancement



Ultra-high Efficiency

Capable to extend travels with the u-shaped stators; Offers length of 135 mm / 270 mm and 156 mm / 312 mm



Continuous-path Movement

Coreless structure without cogging forces; Suitable for applications that require smooth continuous movements, such as electronics assembly, semiconductors and optical inspections

Product Introduction

Delta's U-shaped linear motor is designed with a coreless structure that features high dynamic response, low speed ripple, and is easy to install without cogging force, abrasion, backlash or travel limits. The rated thrust is from 13 to 377N, which is suitable for applications with continuous-path movements demands, such as electronic components and assembly, semiconductors, and optical inspections.

Product Advantages

- ▶ Built-in hall and temperature sensors for all models in the series, no need for extra installation
- ▶ Special design to reduce temperature rise; Avoids the changes of temperature that affect equipment precision
- ▶ Executive magnetic design to optimize unit thrust (with Delta's Servo Drive)
- ▶ Builds complete motion control solution* with controllers, drives, and linear encoders

* Notes:

- For the specifications of the controllers, please refer to Delta's official website
- For the specifications of the servo drives, please refer to page 56
- For the specifications of linear encoders, please refer to page 52

Ordering Information

Coil assembly

ECM-PU 381 D2 H N D D T

Code	Product
ECM-PU	Coreless U-shape Linear Motor

Code	Magnetic Way Thickness, Coil
211	21 mm · 1 coil
212	21 mm · 2 coil
381	38 mm · 1 coil
382	38 mm · 2 coil
383	38 mm · 3 coil
384	38 mm · 4 coil
432	43 mm · 2 coil
433	43 mm · 3 coil
434	43 mm · 4 coil
435	43 mm · 5 coil

Code	Voltage
D2	220V

Code	Sensors
H	Includes hall and temperature sensors

Code	Cooling
N	Natural Cooling

Code	Type
T	Standard Products

Code	Wiring Type
D	Fast Switch

Code	Wiring Length
D	0.5m

Magnet way

ECM-PU M 21 135 T

Code	Product
ECM-PU	Coreless U-shape Linear Motor

Code	Type
M	Magnetic Way

Code	Magnetic Way Thickness
21	21 mm
38	38 mm
43	43 mm

Code	Type
T	Standard Product

Code	Magnetic Way Length
XXX	Magnetic Way Thickness 21 mm Two models: 135 mm / 270 mm
Examples: 135 = 135 mm 156 = 156 mm	Magnetic Way Thickness 38 mm Two models: 156 mm / 312 mm
	Magnetic Way Thickness 43 mm Two models: 156 mm / 312 mm

Thrust Range

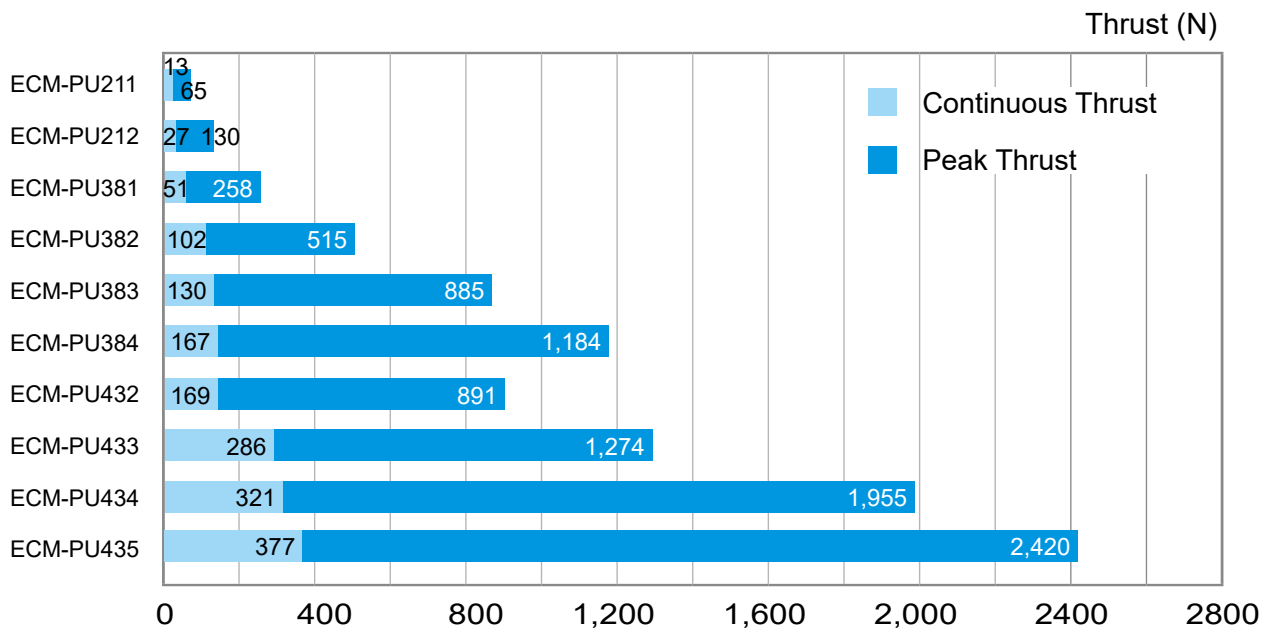

Product Specifications

Electrical specifications

ECM-PU	211	212	381	382	383	384	432	433	434	435
Rated Thrust (N)	13	27	51	102	130	167	169	286	321	377
Peak Thrust (N)	65	130	258	515	885	1184	891	1274	1955	2420
Rated Current (Arms)	1.5	1.5	2.1	2.1	3.0	2.9	2.1	2.3	3.6	3.4
Peak Current (Arms)	7.1	7.1	10.6	10.6	21.2	21.2	10.6	10.6	21.2	21.2
Rated Power (W)	10	18	33	66	73	91	90	167	154	172
Peak Power (W)	226	431	843	1685	3640	4854	2292	3556	5326	6674
Thrust Constant (N/Arms)	9.2	18.4	24.3	48.6	43.3	57.6	80.5	124.3	89.2	110.9
BEMF Constant (V ^{pk} /m/s)	7.5	15.0	19.9	39.7	34.1	45.6	68.6	98.1	75.3	93.2
Motor Constant (N/√W)	4.3	6.3	8.9	12.6	15.2	17.5	17.8	22.1	25.9	28.8
Armature Resistance (Ohm, L-L)	3.0	5.8	5.0	10.0	5.4	7.2	13.6	21.1	7.9	9.9
Armature Inductance (mH, L-L)	0.65	1.3	3.3	6.5	3.4	4.5	9.2	13.8	5.2	6.6
Electric Constant (ms)	0.22	0.23	0.66	0.65	0.63	0.63	0.68	0.65	0.66	0.67
Weight of Coil Assembly (kg)	0.15	0.17	0.3	0.6	0.9	1.2	1.1	1.6	2.1	2.6
Weight of Magnetic Way (kg/m)	5.2		13.1				29.0			
Magnetic Pole Pitch (mm)	27		39							
Air Gap (mm)	0.50		0.75				0.80			
Vertical Attraction Force (N)	0									
Allowable Winding Temp. (°C)	110									
Insulation Resistance	>10 MΩ · 500 V _{DC}									
Withstand Voltage	1,500 V _{AC} · 60 sec									
Operating Ambient Temp. (°C)	0~+40									
Storage Temp. (°C)	-10~+80									
Operating Relative Humidity (RH)	20 ~ 80% (Non-condensing)									
Storage Humidity (RH)	20 ~ 80% (Non-condensing)									
Approvals	CE									
Magnetic Way Length (mm)	135 / 270				156 / 312					
ASD Servo Drive	A3-0221- □		A3-0421- □		A3-0721- □		A3-0421- □		A3-0721- □	

* Note: Specifications tolerance - inductance ±30%, all others ±10%

Product Specifications

Thrust-speed curves

ECM-PU211

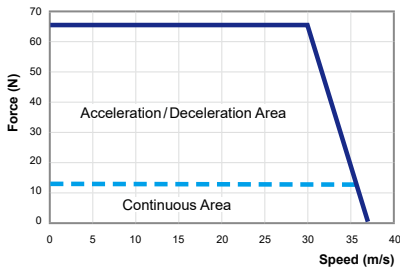

ECM-PU212

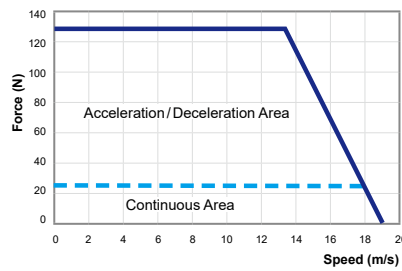

ECM-PU381

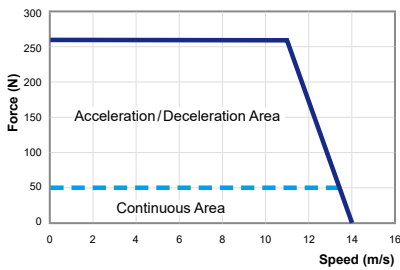

ECM-PU382

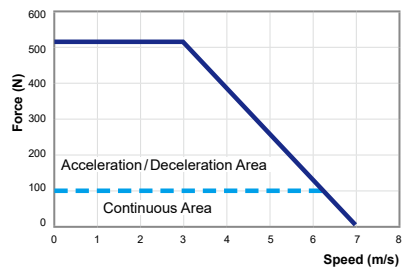

ECM-PU383

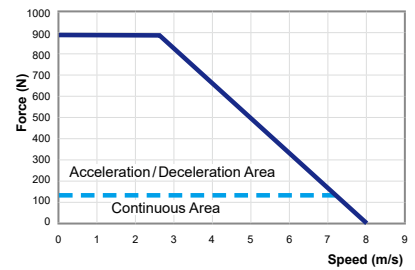

ECM-PU384

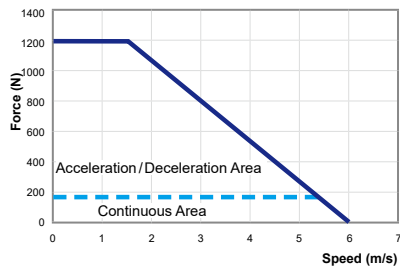

ECM-PU432

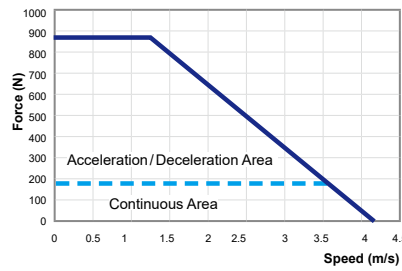

ECM-PU433

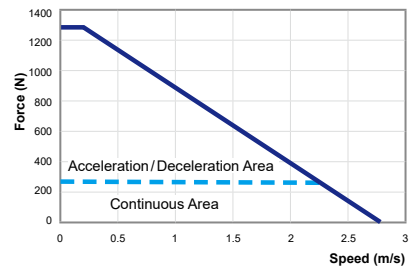

ECM-PU434

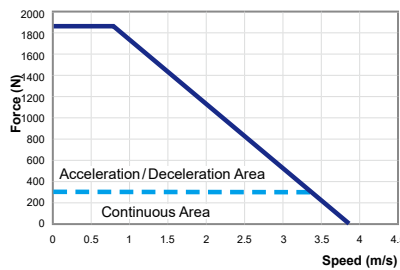

ECM-PU435

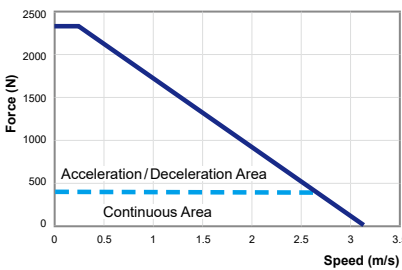

Product Dimensions

Rotor dimensions, ECML-PU21 Series

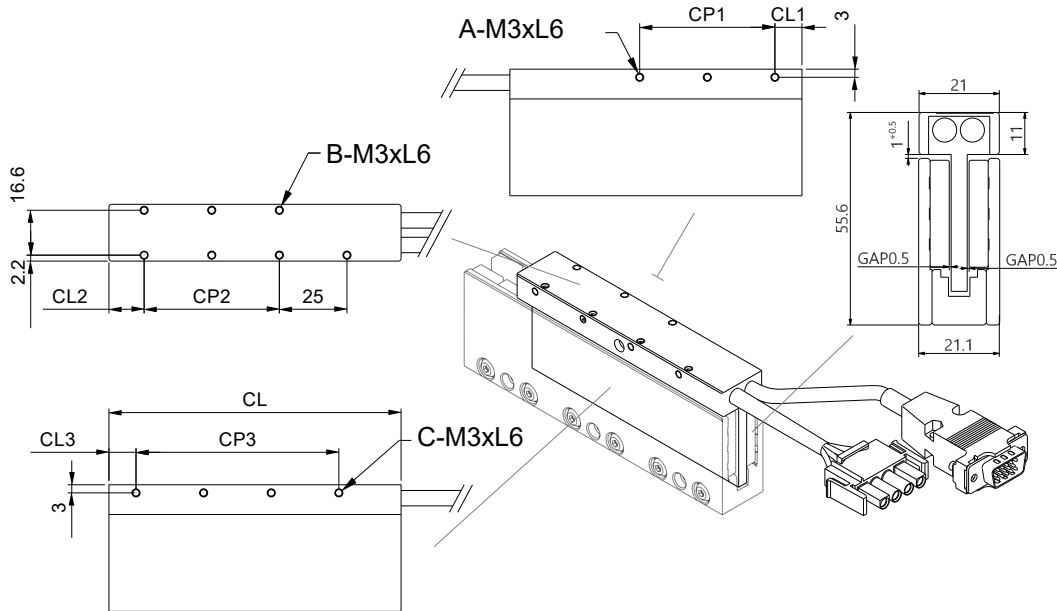

Rotor Models	Rotor Dimensions (mm)									
	CL	CL1	CL2	CL3	CP1	CP2	CP3	A	B	C
ECM-PU211D2HNDDT	59	11	14	11	N/A	N/A	1x25	1	3	2
ECM-PU212D2HNDDT	108	10	13	10	2x25	2x25	3x25	3	7	4

Stator dimensions, ECM-PU21 Series

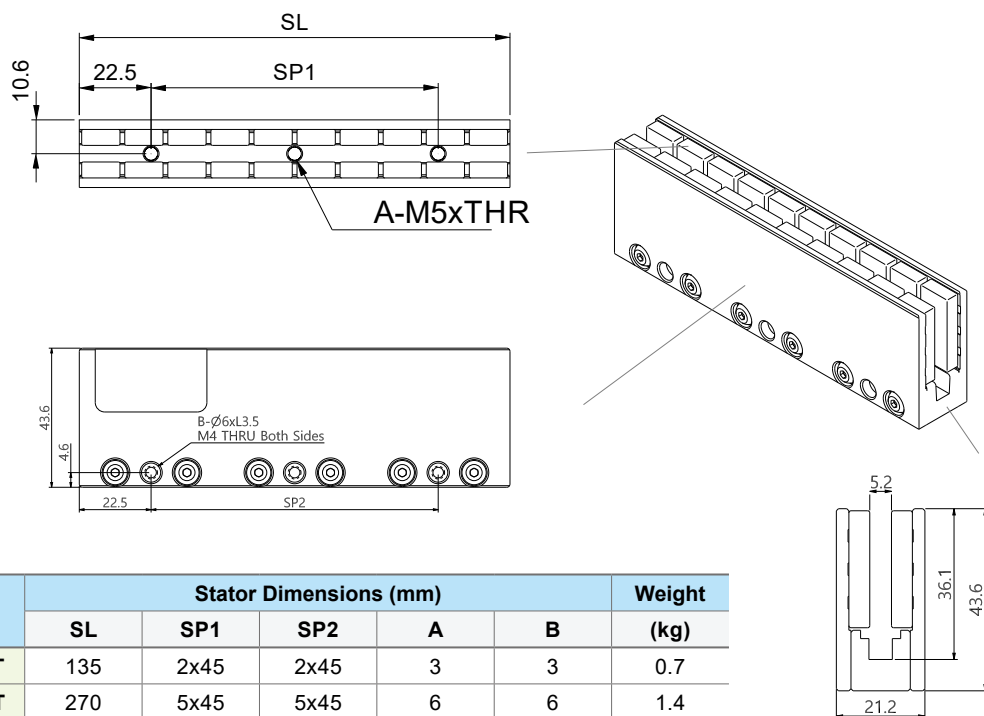

Stator Models	Stator Dimensions (mm)					Weight (kg)
	SL	SP1	SP2	A	B	
ECM-PUM21135T	135	2x45	2x45	3	3	0.7
ECM-PUM21270T	270	5x45	5x45	6	6	1.4

Product Dimensions

Rotor dimensions, ECML-PU38 Series

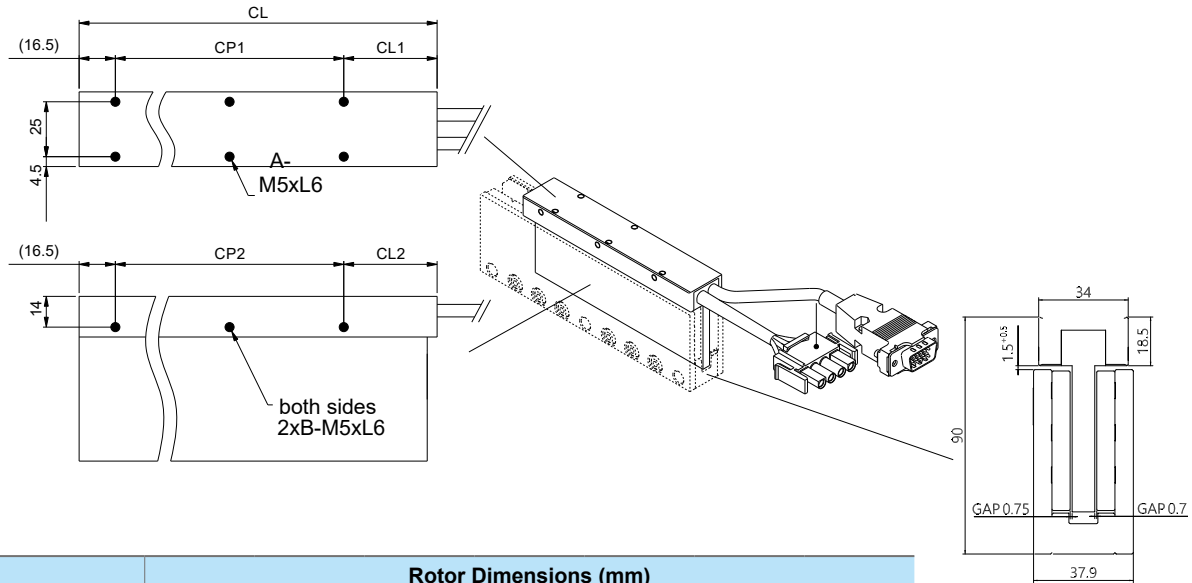

Rotor Models	Rotor Dimensions (mm)						
	CL	CL1	CL2	CP1	CP2	A	B
ECM-PU381D2HNDDT	85	16.5	16.5	52	52	4	2
ECM-PU382D2HNDDT	163	42.5	42.5	2x52	2x52	6	3
ECM-PU383D2HNDDT	241	16.5	16.5	4x52	4x52	10	5
ECM-PU384D2HNDDT	319	42.5	42.5	5x52	5x52	12	6

Stator dimensions, ECM-PU38 Series

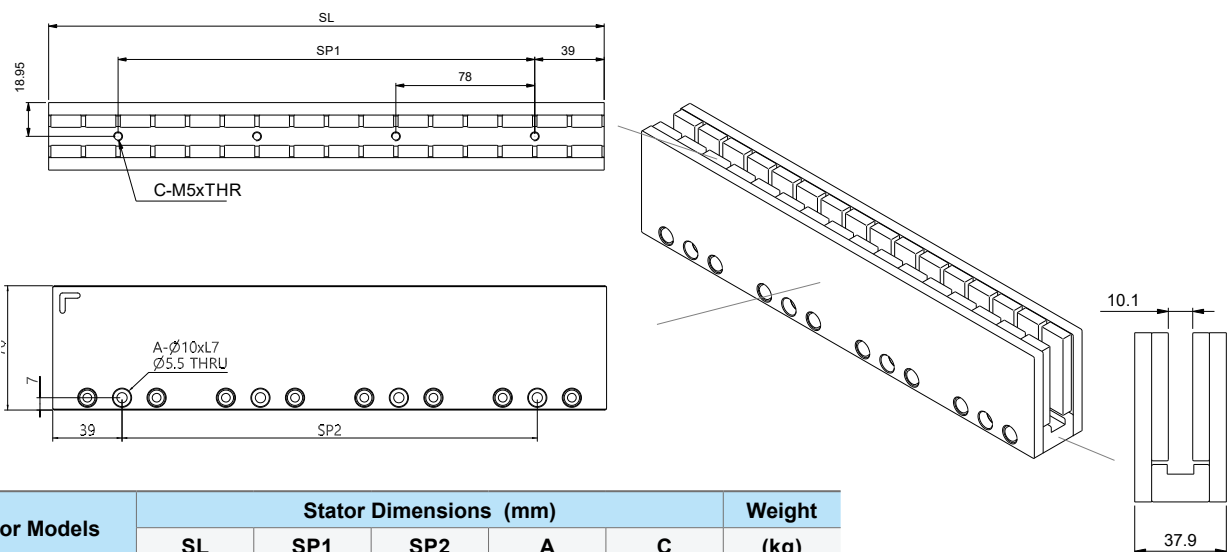

Stator Models	Stator Dimensions (mm)					Weight (kg)
	SL	SP1	SP2	A	C	
ECM-PUM38156T	156	78	78	2	2	2.04
ECM-PUM38312T	312	3x78	3x78	4	4	4.08

Rotor dimensions, ECML-PU43 Series

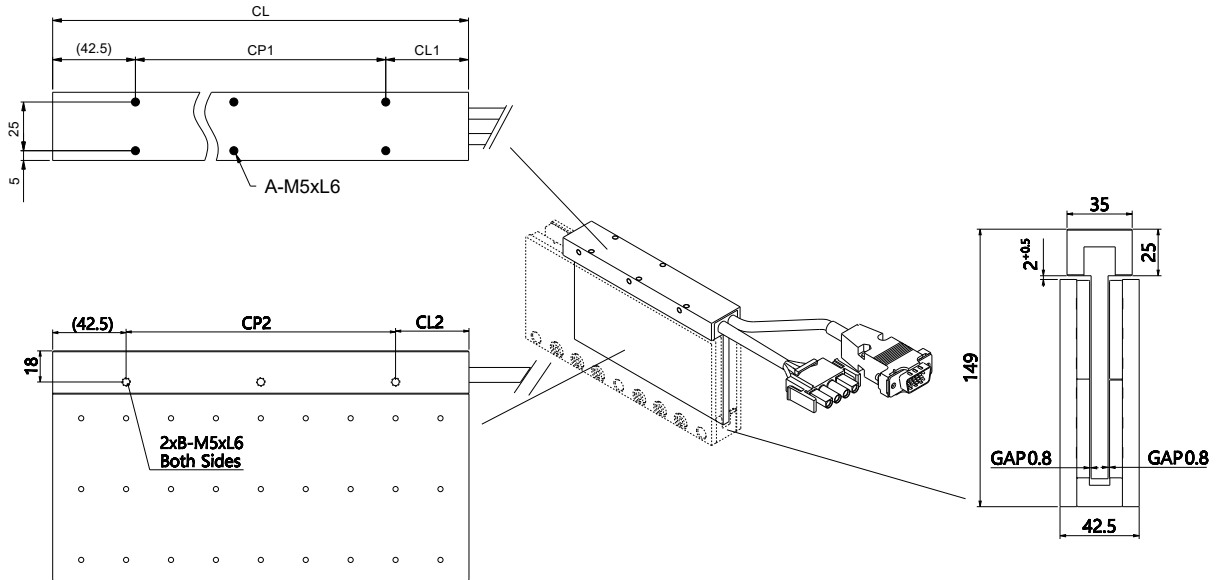

Rotor Models	Rotor Dimensions (mm)						
	CL	CL1	CL2	CP1	CP2	A	B
ECM-PU432D2HNDDT	163	42.5	42.5	78	78	4	2
ECM-PU433D2HNDDT	241	42.5	42.5	2 x 78	2 x 78	6	3
ECM-PU434D2HNDDT	319	42.5	42.5	3 x 78	3 x 78	8	4
ECM-PU435D2HNDDT	397	42.5	42.5	4 x 78	4 x 78	10	5

Stator dimensions, ECM-PU43 Series

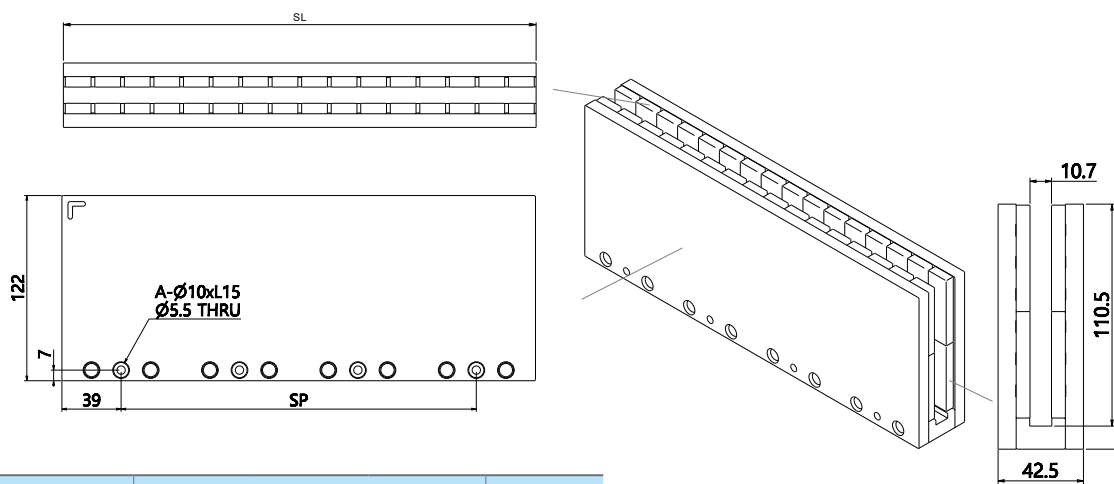

Stator Models	Stator Dimensions (mm)			Weight (kg)
	SL	SP	A	
ECM-PUM43156T	156	78	2	4.53
ECM-PUM43312T	312	3x78	4	9.05

Flat Iron Core Linear Motor ECM-PF Series



High Thrust Density

Iron-core structure enables bigger unit thrust compared to coreless linear motors; Bigger thrust for the same sizes



No Travel Limits

Capable of extending travels with the iron flat stators; Offers lengths of 128 mm and 320 mm



Multiple Rotors Simultaneous Movement

The single-shaft stator on the fixed travel supports multiple rotors to move individually for space utilization and production efficiency enhancement



End-to-end Applications

Features big thrust and high acceleration / deceleration; Suitable for high-load applications that require fast and precise end-to-end movements, such as semiconductors, machine tools, panels, and logistics

Product Introduction

Delta's flat iron core linear motor is designed with an ironcore structure that features high thrust density, high dynamic response, and is easy to install without abrasion, backlash, or travel limits. The rated thrust is from 125 to 1,000N, which is suitable for applications with long-travel, high-speed and high-load movements demands, such as electronics, semiconductors, machine tools, panels, laser processing, logistics and painting.

Product Advantages

- ▶ Built-in hall and temperature sensors for all models in the series, no need for extra installation
- ▶ Special design to reduce temperature rise; Avoids the changes of temperature that affect equipment precision.
- ▶ Executive magnetic design to optimize unit thrust (with Delta Servo Drive)
- ▶ Builds a complete motion control solution* with controllers, drives, and linear encoders

* Notes:

- For the specifications of the controllers, please refer to Delta's official website
- For the specifications of the servo drives, please refer to page 56
- For the specifications of linear encoders, please refer to page 52

Ordering Information

Coil assembly

ECM-PF 801 D2 H N D D T

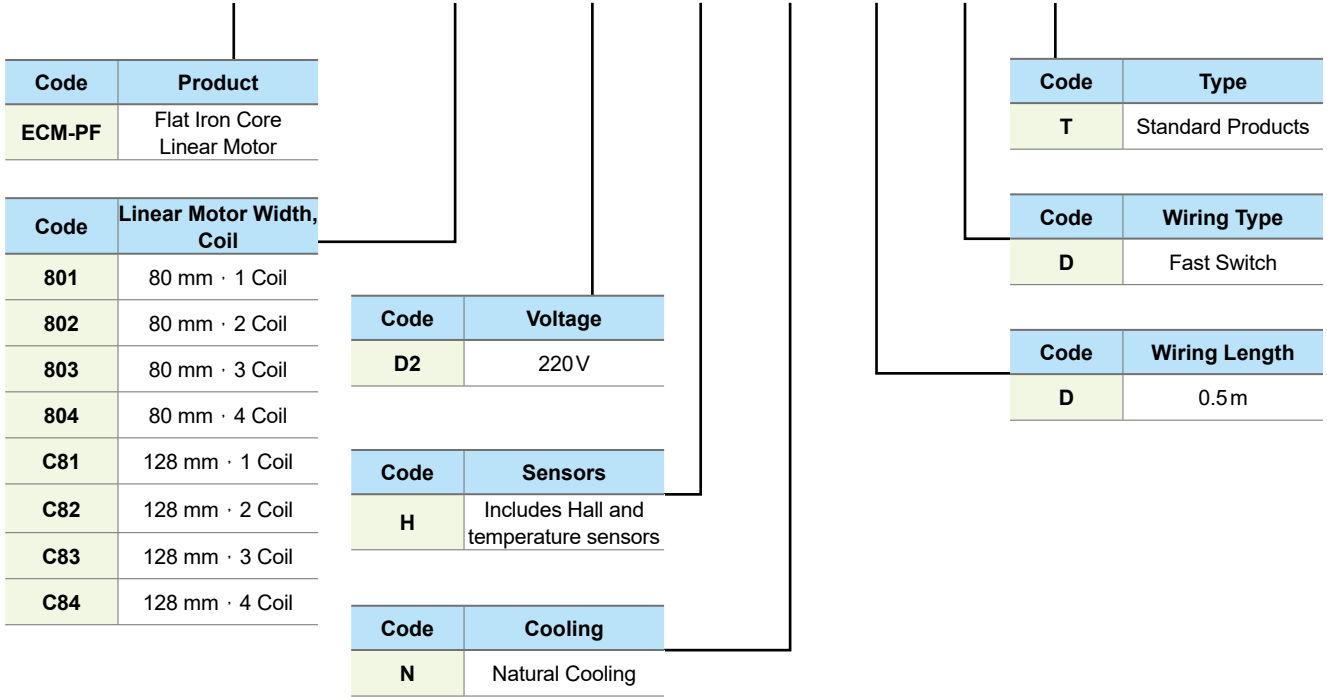

Magnetic way

ECM-PF M 80 128 T

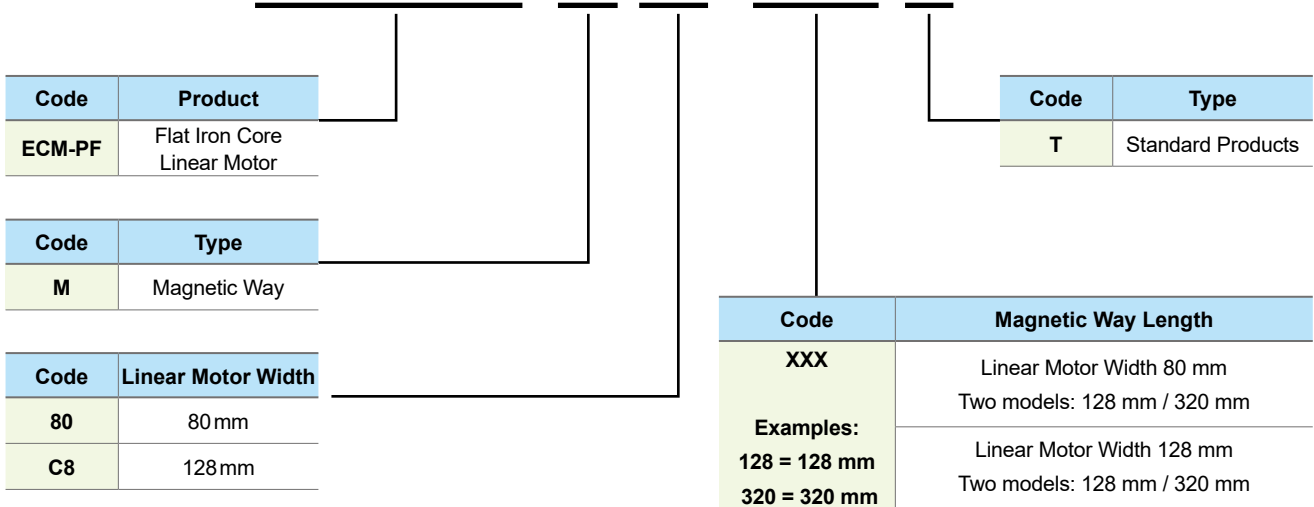

Thrust Range

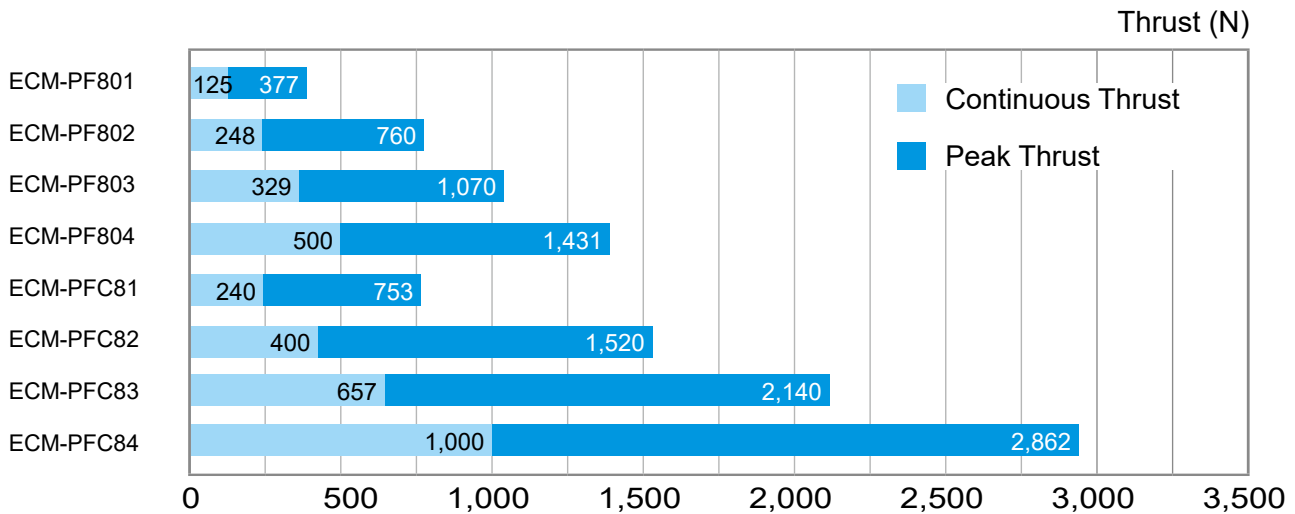

Product Specifications

Electrical specifications

ECM-PF	801	802	803	804	C81	C82	C83	C84
Rated Thrust (N)	125	248	329	500	240	400	657	1000
Peak Thrust (N)	377	760	1070	1431	753	1520	2140	2862
Rated Current (Arms)	2.6	2.6	13.4	10.2	2.5	2.1	13.4	10.2
Peak Current (Arms)	9.2	9.2	48.0	32.0	9.2	9.2	48.0	32.0
Rated Power (W)	61.4	122.7	132.0	229.4	94.9	134	220.9	385.5
Peak Power (W)	761.0	1519.6	1695.6	2260.7	1270.9	2543.1	2837.5	3798.7
Thrust Constant (N/Arms)	47.9	95.2	24.5	49.0	95.8	190.4	49.0	98.0
BEMF Constant ($V^{pk}/m/s$)	41.2	80.1	20.4	40.7	82.3	160.1	40.9	81.3
Motor Constant (N/ \sqrt{W})	15.9	22.3	28.6	33.0	24.6	34.5	44.2	50.9
Armature Resistance (Ohm, L-L)	6.1	12.1	0.5	1.5	10.1	20.3	0.8	2.5
Armature Inductance (mH, L-L)	41.3	84.4	4.0	11.9	74.1	153.3	7.2	21.8
Electric Constant (ms)	6.8	7.0	8.2	8.1	7.3	7.6	8.8	8.8
Weight of Coil Assembly (kg)	0.8	1.6	2.4	3.2	1.5	2.8	4.1	5.4
Weight of Magnetic Way (kg/m)	4.1				7.6			
Magnetic Pole Pitch (mm)	32							
Air Gap (mm)	0.45							
Vertical Attraction Force (N)	638	1275	1913	2550	1275	2550	3825	5100
Allowable Winding Temp. (°C)	110							
Insulation Resistance	$>10 M\Omega \cdot 500 V_{DC}$							
Withstand Voltage	$1,500 V_{AC} \cdot 60sec$							
Operating Ambient Temp. (°C)	0~+40							
Storage Temp. (°C)	-10~+80							
Operating Relative Humidity (RH)	20 ~ 80% (Non-condensing)							
Storage Humidity (RH)	20 ~ 80% (Non-condensing)							
Approvals	CE							
Magnetic Way Length (mm)	128/312							
ASD Servo Drive	A3-0421- □	A3-2023- □		A3-0421- □		A3-2023- □		

* Notes:

- Specifications tolerance - inductance $\pm 30\%$, all others $\pm 10\%$
- Magnetic attraction between rotors and stators is strong. Please be aware of pinching and avoid absorption

Thrust-speed curves

ECM-PF801

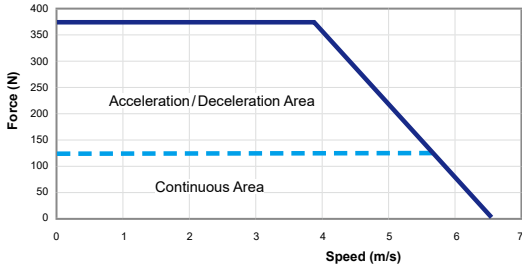

ECM-PF802

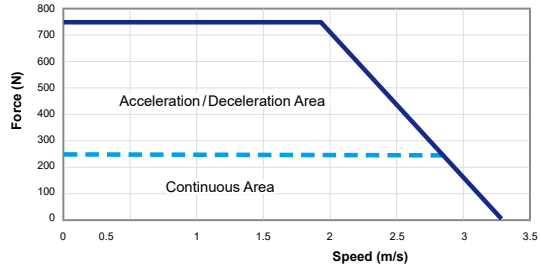

ECM-PF803

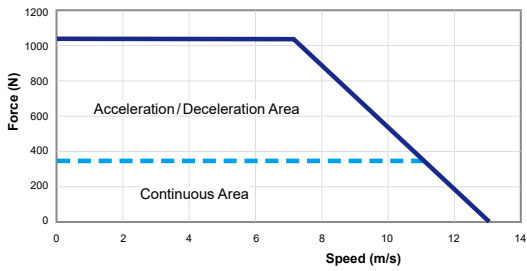

ECM-PF804

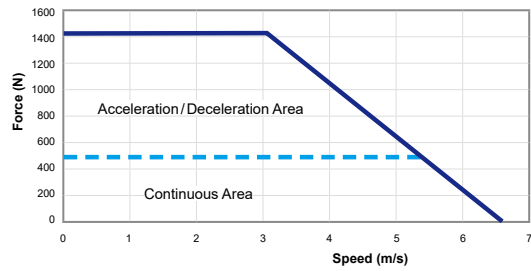

ECM-PFC81

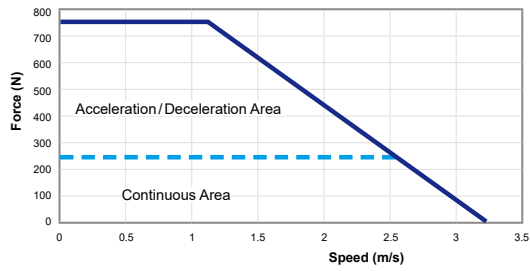

ECM-PFC82

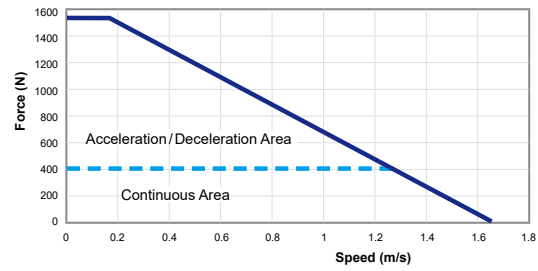

ECM-PFC83

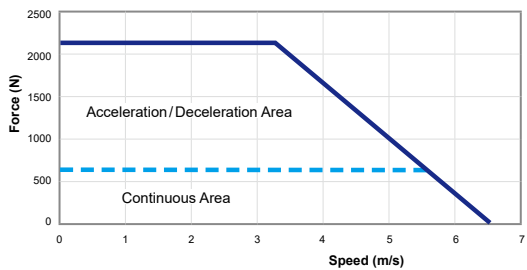

ECM-PFC84

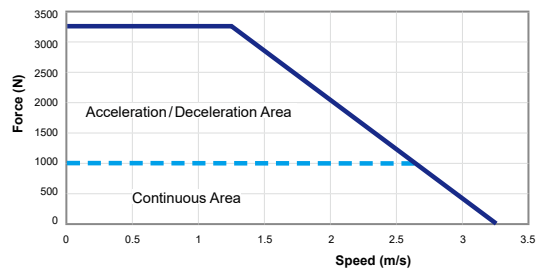

Product Dimensions

Rotor dimensions, ECM-PF80 Series

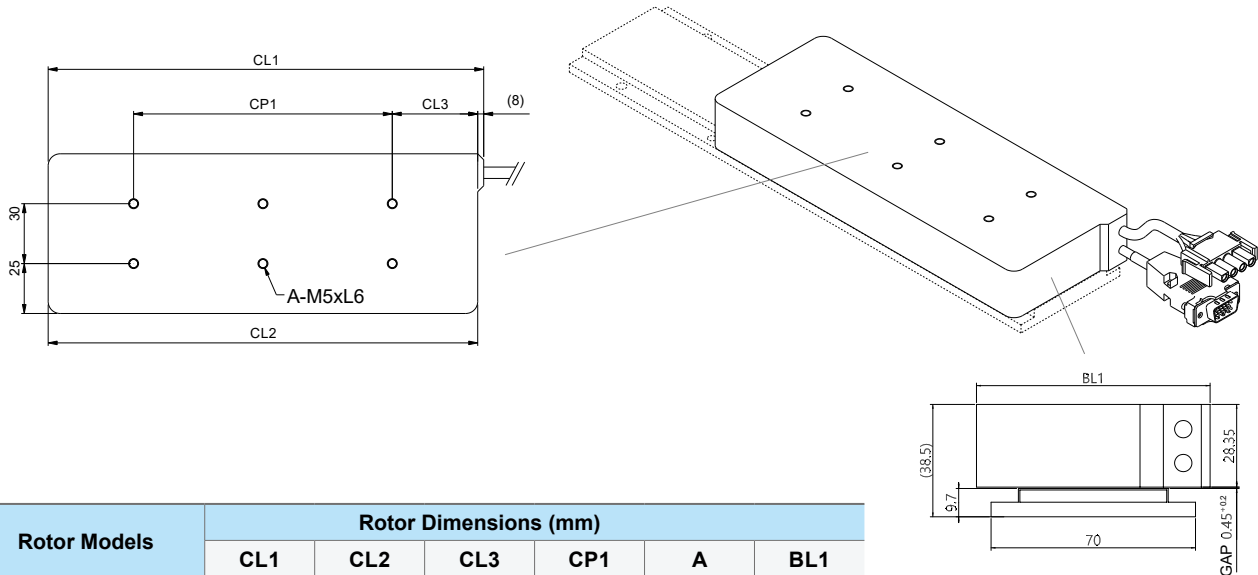

Rotor Models	Rotor Dimensions (mm)					
	CL1	CL2	CL3	CP1	A	BL1
ECM-PF801D2HNDDT	93.6	85.6	21.2	1x43.2	4	80
ECM-PF802D2HNDDT	158.4	150.4	42.8	1x64.8	4	80
ECM-PF803D2HNDDT	223.2	215.2	42.8	2x64.8	6	86
ECM-PF804D2HNDDT	288	280	42.8	3x64.8	8	86

Stator dimension, ECM-PF80 Series

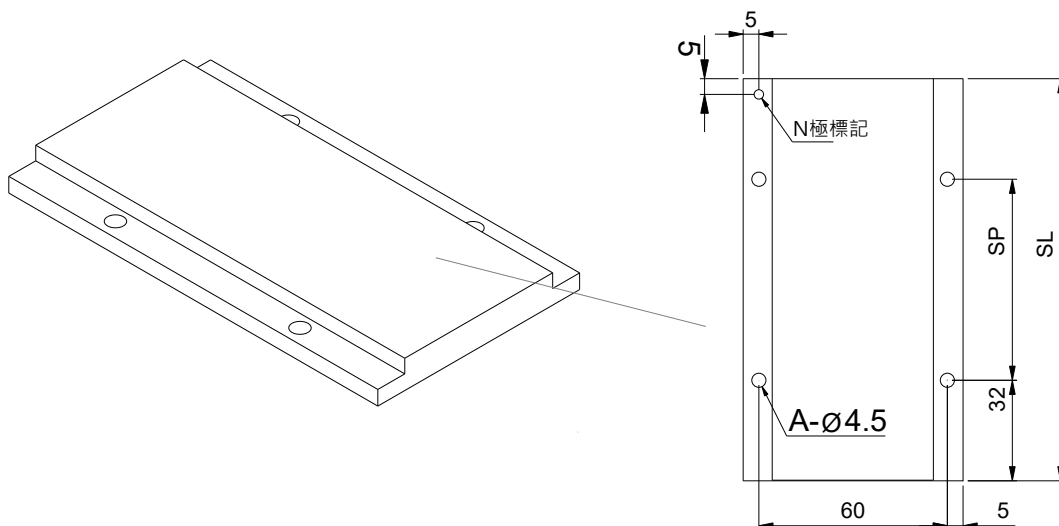

Stator Models	Stator Dimensions (mm)			Weight (kg)
	SL	SP	A	
ECM-PFM80128T	128	1 x 64	4	0.53
ECM-PFM80320T	320	4 x 64	10	1.31

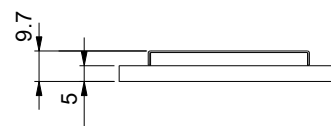

* Note: The magnetic force between rotor and stator is extremely strong; Be aware of pinch or absorption between rotors and stators

Rotor dimensions, ECM-PFC8 Series

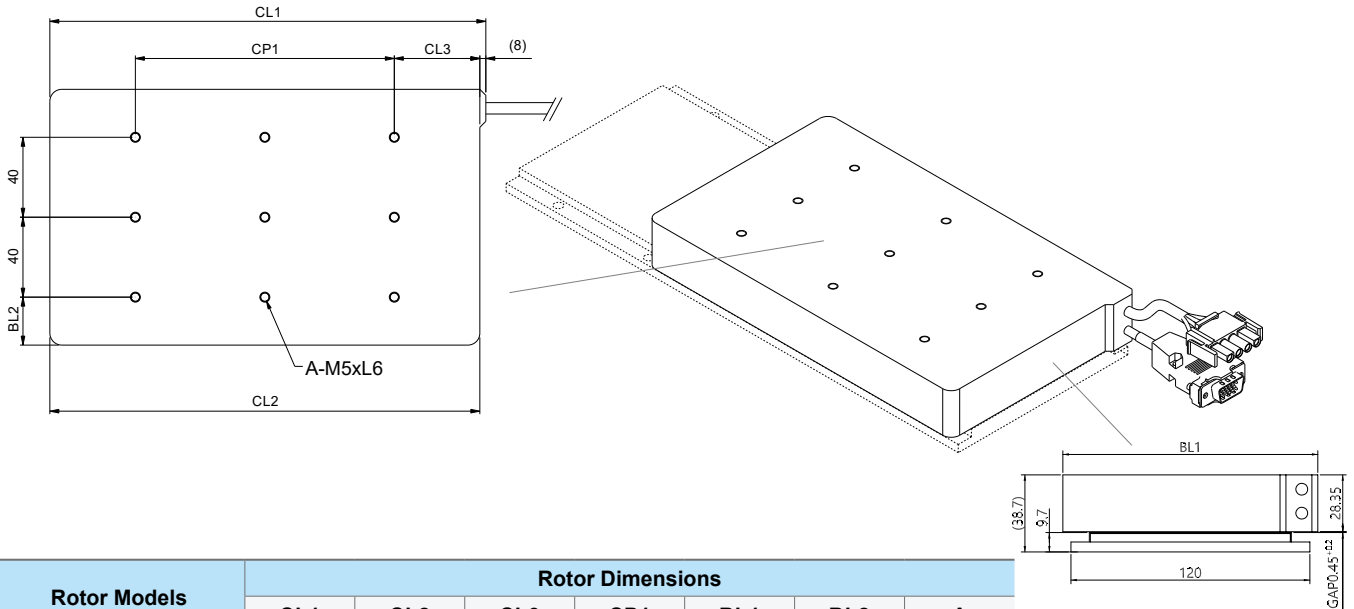

Rotor Models	Rotor Dimensions						
	CL1	CL2	CL3	CP1	BL1	BL2	A
ECM-PFC81D2HNDDT	93.6	85.6	21.2	1x43.2	128	24	6
ECM-PFC82D2HNDDT	158.4	150.4	42.8	1x64.8	128	24	6
ECM-PFC83D2HNDDT	223.2	215.2	42.8	2x64.8	134	27	9
ECM-PFC84D2HNDDT	288	280	42.8	3x64.8	134	27	12

Stator dimensions, ECM-PFMC8 Series

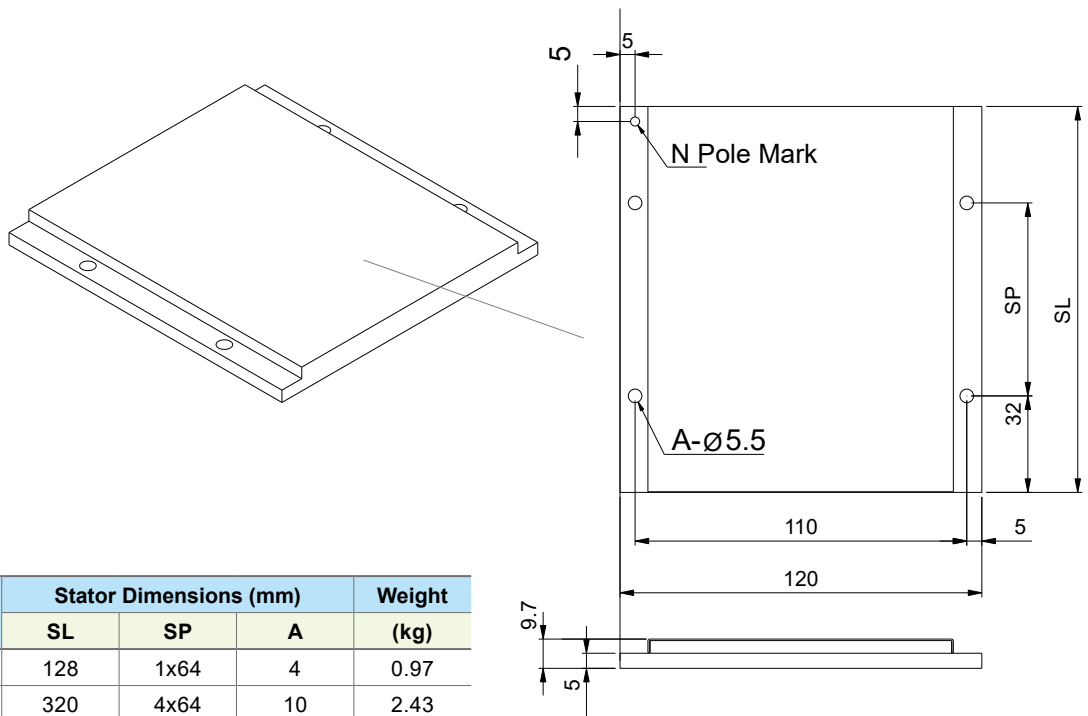

Stator Models	Stator Dimensions (mm)			Weight (kg)
	SL	SP	A	
ECM-PFMC8128T	128	1x64	4	0.97
ECM-PFMC8320T	320	4x64	10	2.43

* Note: The magnetic force between rotor and stator is extremely strong; Be aware of pinch or absorption between rotors and stators

Wiring and Extension Cable Specifications

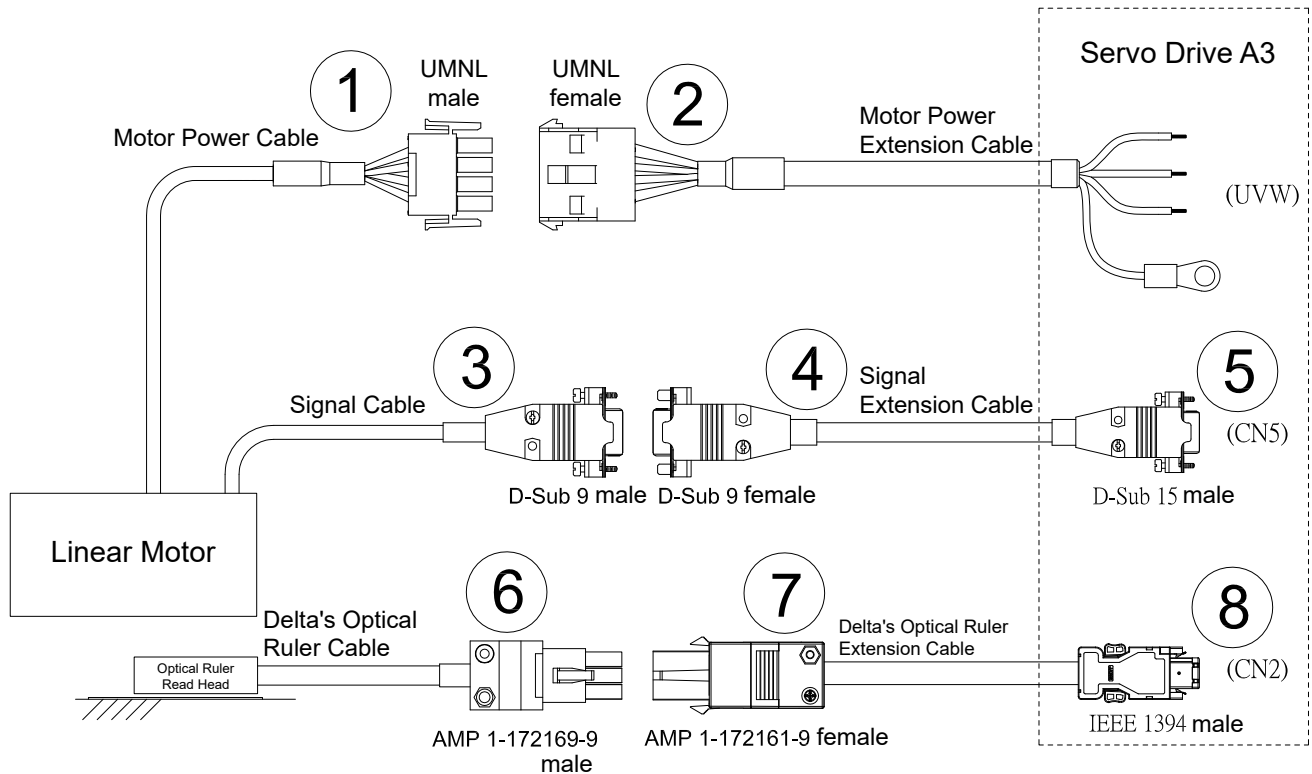

Extension cable models, linear motors

Types	Models	Specifications (mm)
Power Extension Cables (Withstands a bending test 10 million times)	MEC-PJ1018S	1000±30
	MEC-PJ3018S	3000±50
	MEC-PJ5018S	5000±50
Signal Extension Cables (Withstands a bending test 10 million times)	MEC-SJ1026S	1000±30
	MEC-SJ3026S	3000±50
	MEC-SJ5026S	5000±50
Power Extension Cables (Withstands a bending test 10 million times)	MEC-PJ1017S	1000±30
	MEC-PJ3017S	3000±50
	MEC-PJ5017S	5000±50

* Note: For the listed models: ECM-PF803、ECM-PF804、ECM-PFC83、ECM-PFC84

Extension cable models, Delta's optical ruler

Types	Models	Specifications (mm)
Optical Ruler Extension Cable (Bendable Cable)	ACS3-CAEB1003	3000±50mm
	ACS3-CAEB1005	5000±50mm

* Note: The terminals of the battery box do not need wirings

Pin Definitions

1

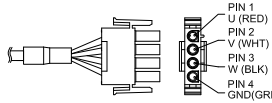

UMNL 04P PLUG HSG

Pin No.	Definition	Color
1	U	RED
2	V	WHT
3	W	BLK
4	GND	GRN

2

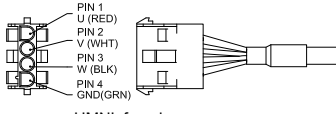

UMNL 04P CAP HSG

Pin No.	Definition	Color
1	U	RED
2	V	WHT
3	W	BLK
4	GND	GRN

3

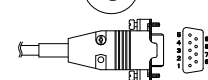

D-Sub 9 male

Wiring definitions of motor signal cables

D-SUB	DESCRIPTION	COLOR
1	Hall U	WHT
2	Hall V	BRN
3	Hall W	BLU
4	Temp +	ORG
5	Temp -	ORG/RED
6		
7	+5V	BLK
8	GND	BLK/RED
9		
case		Shield

4

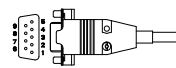

D-Sub 9 female

D-SUB	DESCRIPTION	COLOR
1	Hall U	WHT
2	Hall V	BRN
3	Hall W	BLU
4	Temp +	ORG
5	Temp -	ORG/RED
6		
7	+5V	BLK
8	GND	BLK/RED
9		
case		Shield

5

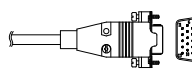

D-Sub 15 male

CODE	DESCRIPTION
1	
2	
3	
4	
5	
6	Encoder grounding
7	Encoder grounding
8	Encoder power
9	
10	Hall sensor U phase input
11	Hall sensor V phase input
12	Hall sensor W phase input
13	Motor temperature detection+
14	Motor temperature detection-
15	
case	Shield

6

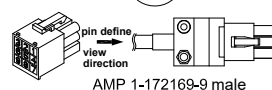

AMP 1-172169-9 male

AMP	DESCRIPTION	COLOR
1	T+	WHT
2	N/A	
3	N/A	
4	T-	WHT/RED
5	N/A	
6	N/A	
7	+5V	BRN
8	GND	BLU
9		Shield

7

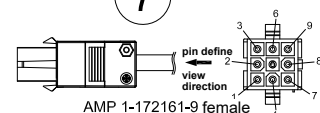

AMP 1-172161-9 female

AMP	DESCRIPTION	COLOR
1	T+	WHT
2	N/A	
3	N/A	
4	T-	WHT/RED
5	N/A	
6	N/A	
7	+5V	BRN
8	GND	BLU
9		Shield

8

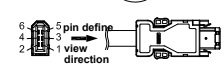

IEEE 1394 male

IEEE	DESCRIPTION	COLOR
1	5V	BRN
2	GND	BLU
3		
4		
5	T+	WHT
6	T-	WHT/RED
case		Shield

* Note: For the listed models: ECM-PF803 · ECM-PF804 · ECM-PFC83 · ECM-PFC84

1*

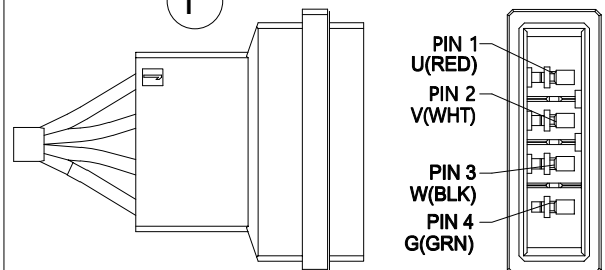

PIN 1 U (RED)
PIN 2 V (WHT)
PIN 3 W (BLK)
PIN 4 G (GRN)

4200S TAB HSG 4P F/H X		
Pin No.	Definition	Color
1	U	Red
2	V	White
3	W	Black
4	GND	Green

2*

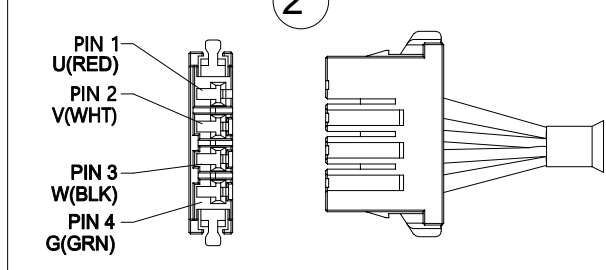

PIN 1 U (RED)
PIN 2 V (WHT)
PIN 3 W (BLK)
PIN 4 G (GRN)

D4200S REC HSG 4P/X		
Pin No.	Definition	Color
1	U	Red
2	V	White
3	W	Black
4	GND	Green

Linear Modules

Product Overview



Linear Pocket Actuator LPL

- ▶ Continuous Thrust 5~37N
- ▶ Peak Thrust 16~111N

Suitable for precise pick, place, and press on Z axis



Linear Motor Driven Linear Stage LA-S Series

LA-S

- ▶ Continuous Thrust 44~185N
- ▶ Peak Thrust 177~740N

Suitable for semiconductors and electronics assembly



Ball Screw Driven Linear Stage LU Series

LU

- ▶ Continuous Thrust 150~905N
- ▶ Peak Thrust 450~2,714N

Suitable for general servo scenarios



Linear Pocket Actuator LPL Series

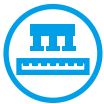

Direct Driven Structure

Linear motor driven features high speed, high precision, lightweight and with no backlash or abrasion



Soft Landing Features

Capable of slow contact and precise pressing control with the soft landing features of Delta's servo drives to avoid component damage



Precise Force Control

Integrated one-unit design for less deviations; Capable to achieve high-precision force control with Delta's servo drives

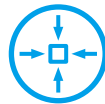

Lightweight

Small size to save space. Capable of side-by-side installation. Suitable for precise pressing and fast pick and place z-axis applications, such as electronic components, lens, and wafer production

Product Introduction

Delta Linear Pocket Actuator LPL Series integrates linear motors, linear encoders, and rails in one unit. It is lightweight and easy to install. The rated thrust is 5N and 1,000N, which is suitable for high-speed motion, precise pressing and assembly applications, such as electronics and assembly, semiconductor packaging and test, lens, and other small-scale z-axis applications.

Product Advantages

- ▶ Low thrust and short travel; the acceleration is up to 10 G
- ▶ Fine force analysis; the minimum is within 0.1N
- ▶ Excellent force repeatability; the minimum thrust is within $\pm 1\%$ (with Delta's servo drives)
- ▶ The whole series includes optical linear encoders with a 0.5 μm resolution

Features

Integrated lightweight linear module; Capable of fulfilling dedicated force control with Delta's servo drives

- LPL Series features compact design and integrates linear motors, rails, optical rulers and other mechanical parts

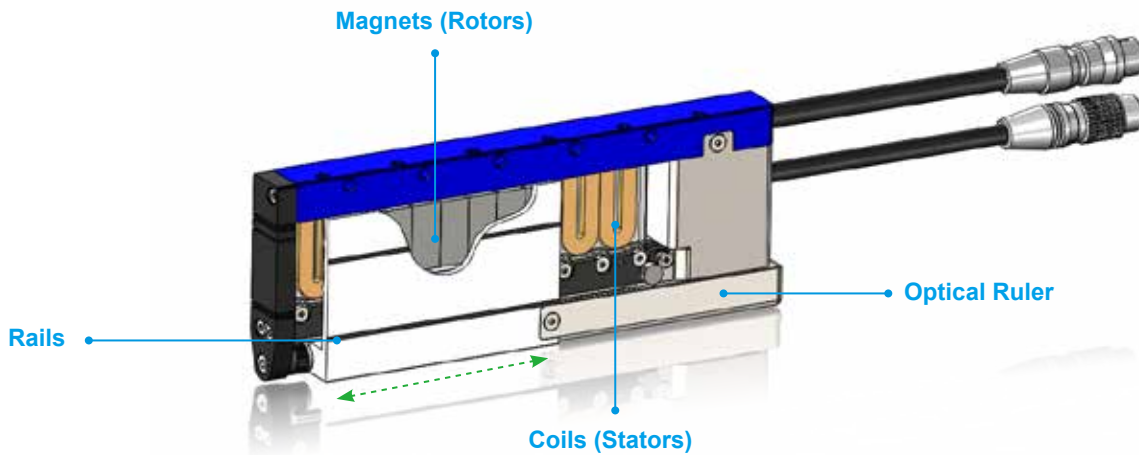

* Note: LPL Series includes high-precision glass optical ruler. Please handle with care and do not drop or press

- LPL Series features soft-landing on the secondary platform with Delta Servo Drive ASDA-A3 Series to avoid damaging the processing parts

Operating Route

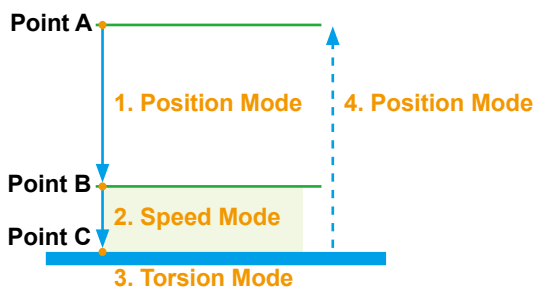

Position-thrust Curves

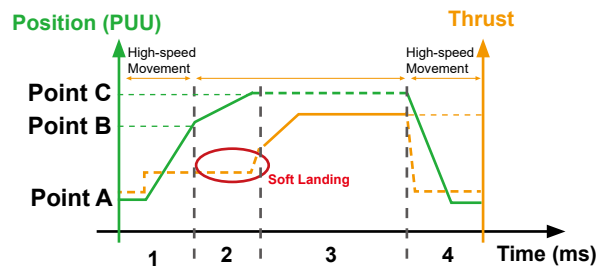

Movement Types	Movement Status	Benefits
1. Position Mode (A to B)	Falls to the default position in high speed	High-speed movements; Reduces processing hours
2. Speed Mode (B to C)	Falls in low speed and gently presses the contact platform (The process is called soft landing)	Gentle contacts; Avoids damaging the processing parts
3. Torsion Mode (C)	Compresses to the default value and retains the pressure for torsion output	Stable torsion; Fulfills production requirements
4. Position Mode (C to A)	Quickly pulls back	High-speed movements; Reduces processing hours

Advantages of Soft Landing

- Linear motor module structure features high speed, high precision, and stability for more precise and timely soft landing
- Breaks down different movement modes to optimize production efficiency and quality yield
- Suitable for precise pressing and assembly applications, such as lens, wafers, electronic components, and other production with easy to damage parts

Ordering Information

LPL 12 A - 020 - X - S

Code	Product
LPL	Linear Pocket Actuator

Code	Width
12	12 mm
31*	31 mm

* Note: Upcoming Model

Code	Series
A	Linear Model
R	Linear and Rotary Model (Coming Soon)

Code	Type
S	Standard Products

Code	Specifications
X	0.5um Optical Ruler

Code	Effective Stroke
020	20 mm
030	30 mm

Product Specifications

Electrical specifications

Specifications	LPL12A-020-X-S	LPL31A-030-X-S
Rated Thrust (N)	4.7	37
Peak Thrust (N)	16.2	111
Rated Current (Arms)	0.7	1.4
Peak Current (Arms)	2.4	4.3
Rated Power (W)	9.4	33.1
Peak Power (W)	110.6	298.3
Thrust Constant (N/Arms)	6.7	26.1
BEMF Constant (Vpk/m/s)	5.6	21.3
Motor Constant (N/√W)	1.5	6.4
Armature Resistance (Ohm, L-L)	12.8	11.0
Armature Inductance (mH, L-L)	1.0	1.88
Electric Constant (ms)	0.1	0.17
Magnetic Pole Pitch (mm)	15	25
Temperature Sensor	X	O
Hall Sensor	X	O
LPL Weight (kg)	0.24	0.55
Encoder Precision (um)	0.5	
Air Gap (mm)	0.5	
Distance (mm)	20	30
Vibration Resistance	1G	
Allowable Winding Temp. (°C)	110	
Insulation Resistance	>10 MΩ · 500 V _{DC}	
Withstand Voltage	1,500 V _{AC} · 60 秒	
Operating Ambient Temp. (°C)	0~40	
Storage Temp. (°C)	-10~80	
Operating Relative Humidity (RH)	20 ~ 80% (Non-condensing)	
Storage Humidity (RH)	20 ~ 80% (Non-condensing)	
ASD Servo Drive	A3-0121- □	A3-0221- □

Thrust-speed curves

LPL12A

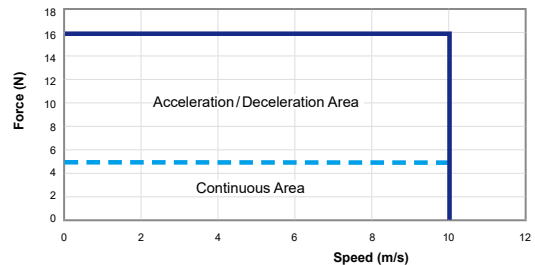

LPL31A*

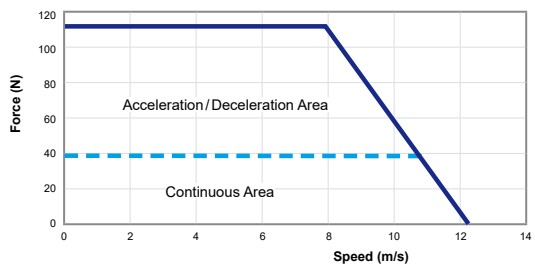

Product Dimensions

LPL12A

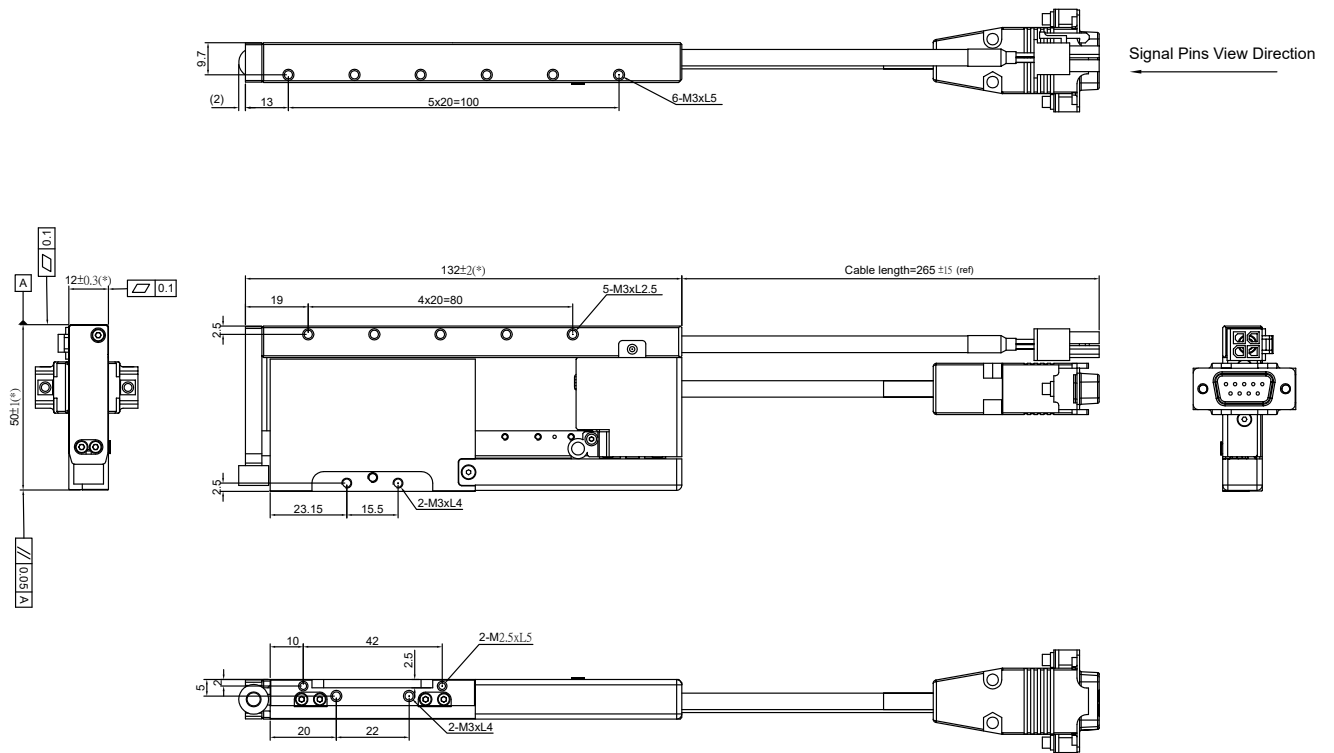

LPL31A *

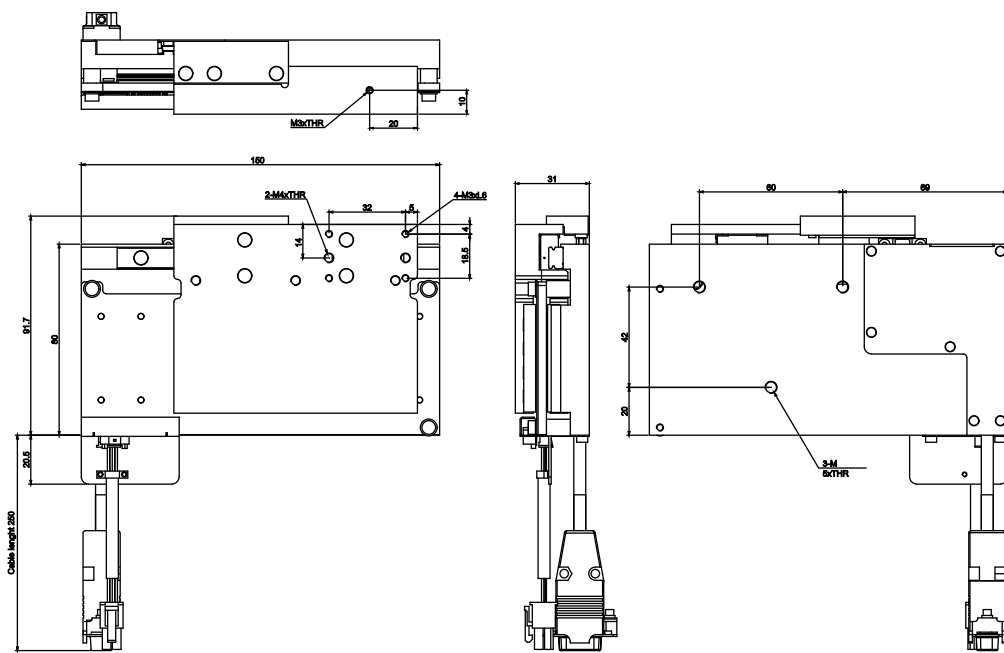

Wiring and Accessory Cable Specifications

Linear actuator wirings

Power Cable C4201HF-2X2P (for AWG#22) (male)

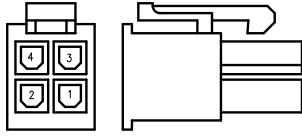

POWER CABLE		
CODE	DESCRIPTION	COLOR
1	U	Red
2	V	White
3	W	Black
4	GND	Green

Signal Cable D-sub 9pin (male)

Signal Cable

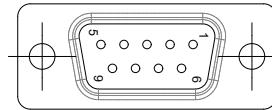

signal	colour	D-sub high density 9pin
+5V	Brown	1
0V	White	8
A+	Green	2
A-	Yellow	5
B+	Blue	3
B-	Red	6
Z+	Pink	4
Z-	Grey	7
	inner shield	-
	outer shield	clamp

Extension cable models and specifications, LPL12A

Cables	Models	L (mm)
Power Cables (bendable)	MEC-PN1026S	1,000 ± 30
	MEC-PN3026S	3,000 ± 50
	MEC-PN5026S	5,000 ± 50
Signal Cables (bendable)	MEC-SN1028P	1,000 ± 30
	MEC-SN3028P	3,000 ± 50
	MEC-SN5028P	5,000 ± 50

Extension cable models and specifications, LPL31A*

Cables	Models	L (mm)
Power Cables (bendable)	MEC-PN1026S	1,000 ± 30
	MEC-PN3026S	3,000 ± 50
	MEC-PN5026S	5,000 ± 50
Signal Cables (bendable)	MEC-TN1016P	1,000 ± 30
	MEC-TN3016P	3,000 ± 50
	MEC-TN5016P	5,000 ± 50

Extension cable wiring

General power cable

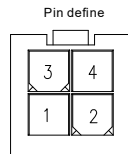

Pin No.	Definition	Color
1	U	Red
2	V	White
3	W	Black
4	GND	Green

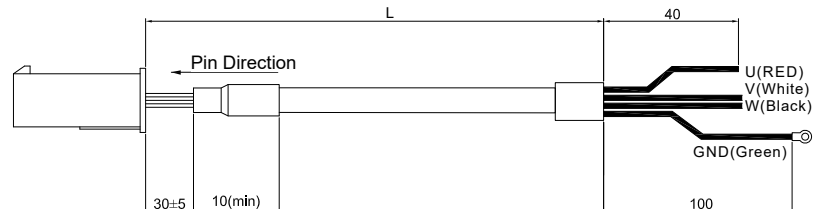

Signal Cable, LPL12A



signal	D-sub HD-9P (female)	D-sub HD-15P (male)
+5V	1	8
0V	8	6
A+	2	4
A-	5	5
B+	3	3
B-	6	2
Z+	4	9
Z-	7	1
	-	-
	clamp	case

Signal Cable, LPL31A*

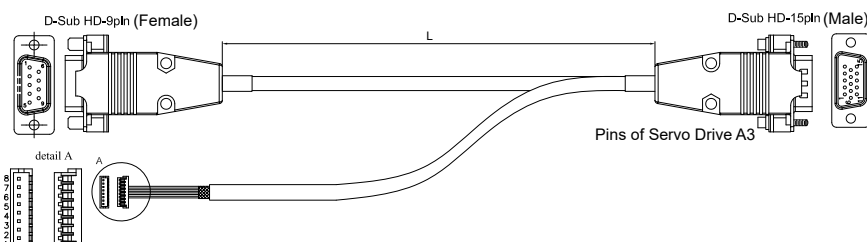

signal	D-sub HD-9P (female)	DF52-8P-0.8C (HIROSE)	D-sub HD-15P (male)
+5V	1	3	8
GND	8	2	6,7
A+	2		4
A-	5		5
B+	3		3
B-	6		2
Z+	4		9
Z-	7		1
Hall U		6	10
Hall V		4	11
Hall W		5	12
Temperature		8	13
Temperature		7	14
Shield	clamp outer shield	1	case

Linear Motor Driven Linear Stage LA-S Series



Stable Speed

Excellent speed stability and low ripple effect; Suitable for applications that require high precision in unit time



Easy to Install

Integrated module in one unit. Easy to install without extra mechanical parts; Saves development costs and resources



Multiple Rotors Simultaneous Movement

Supports multiple rotors on a single shaft to move individually for space utilization and production efficiency enhancement



Continuous-path Movement

Coreless structure without cogging forces; Suitable for applications that require smooth continuous movements, such as electronics assembly, semiconductors and optical inspections

Product Introduction

Delta's Linear Motor Driven Linear Stage LA-S Series integrates linear motors, linear encoders, and rails in one unit. It features high dynamic response, high speed, high precision, and low ripple without abrasion and backlash. The rated thrust is 44 to 185N, which is suitable for applications with continuous movement demands. Contains models with or without cable chains to fit in different scenarios.

Product Advantages

- ▶ Built-in hall and temperature sensors for all models in the series, no need for extra installation
- ▶ Special design to reduce temperature rise; Avoids the changes of temperature to affect equipment precision
- ▶ The whole series includes optical linear rulers with a 1 μm resolution
- ▶ Module structure for direct installation on the equipment

Ordering information

LA - S4 1 015 D 1 M S00

Code	Product
LA	Linear Motor Driven Linear Stag

Code	Linear Motor Models
S4	ECML-S2004
S5	ECML-S2005
S6	ECML-S2504
S7	ECML-S2506
S8	ECML-S2508
SA	ECML-S3206
SB	ECML-S3208

Code	Numbers of Rotors on a Shaft
X	1
	2
Examples:	3
1~9	4,5...9

Code	Effective Stroke
XXX Examples: 015 = 150mm 052 = 520mm 106 = 1060mm 206 = 2060mm	LA-S4 150 ~ 990 mm · one pitch is 60 mm
	LA-S5 180 ~ 960 mm · one pitch is 60 mm
	LA-S6 100 ~ 1,300 mm · one pitch is 60 mm
	LA-S7 120 ~ 1,260 mm · one pitch is 60 mm
	LA-S8 120 ~ 1,200 mm · one pitch is 60 mm
	LA-SA 140 ~ 2,060 mm · one pitch is 60 mm
	LA-SB 140 ~ 2,000 mm · one pitch is 60 mm

Code	Resolution
D	1um Optical ruler

Code	Types
S00	Standard Products

Code	Cover
M	Aluminum Extrusion

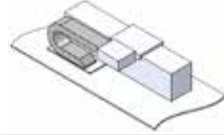
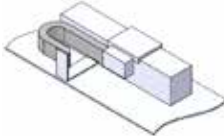
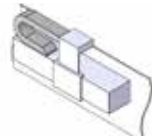
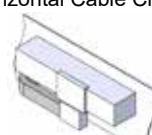
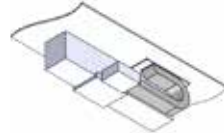
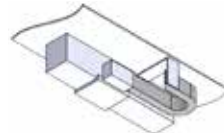
Code	Mounting Direction
0	No Cable Chains
1	Horizontal Mounting (Vertical Cable Chains) 
2	Horizontal Mounting (Horizontal Cable Chains) 
3	Lateral Mounting (Vertical Cable Chains) 
4	Lateral Mounting (Horizontal Cable Chains) 
5	Upside-down Mounting (Vertical Cable Chains) 
6	Upside-down Mounting (Horizontal Cable Chains) 

Thrust Range

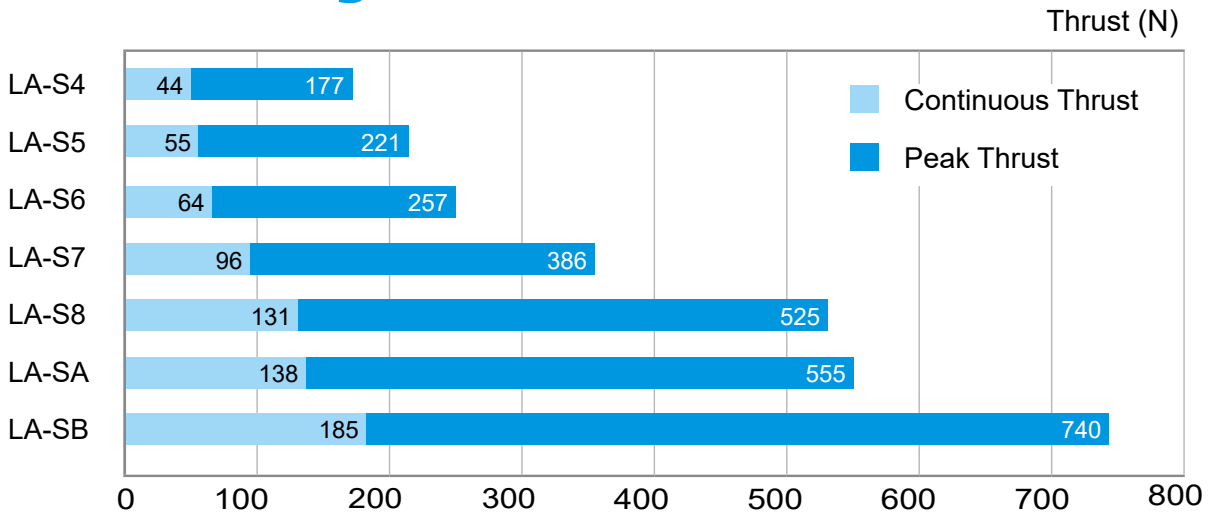

Stroke Range

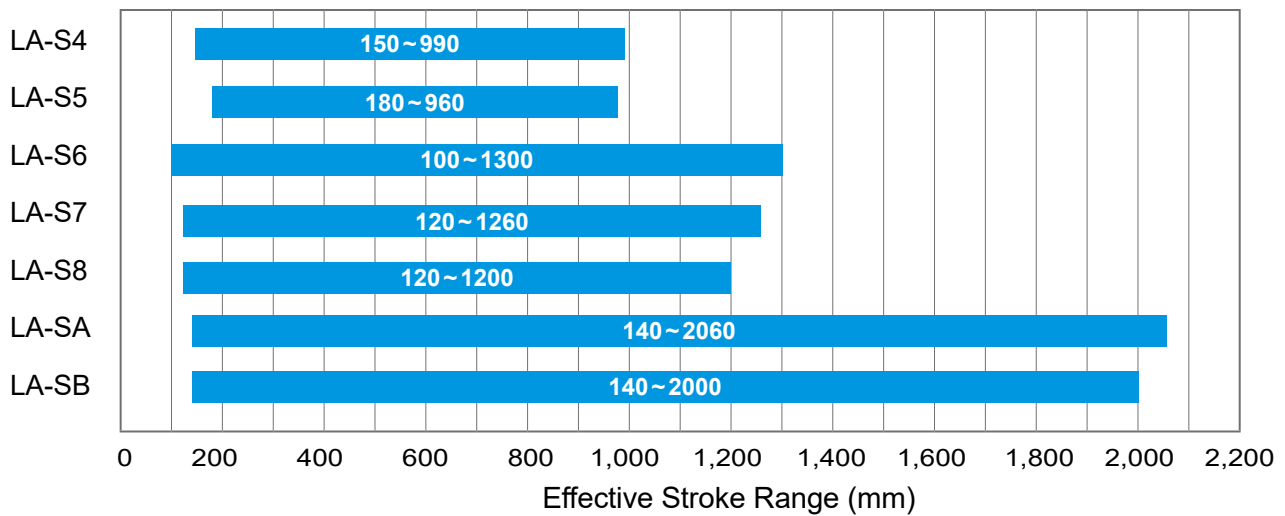

Product Specifications

LA	S4	S5	S6	S7	S8	SA	SB
Peak Thrust (N)	177	221	257	386	525	555	740
Continuous Thrust (N)	44	55	64	96	131	138	185
Max. Velocity (m/s)	4						
Resolution (μm)	1						
Repeatability (μm)	±1						
Moving Part Weight (kg)	2.9	3.3	3.9	4.7	5.7	5.8	6.9
ASD Servo Drive	A3-0221- □		A3-0421- □		A3-0721- □		

Product Dimensions

LA-S4 / LA-S5

ø20 Magnetic way/Effective stroke range: 150~990 mm

Slider dimensions

Unit : mm

Models	Slider Total Length, F	F1	F2
LA-S4	165	135	67
LA-S5	195	165	75

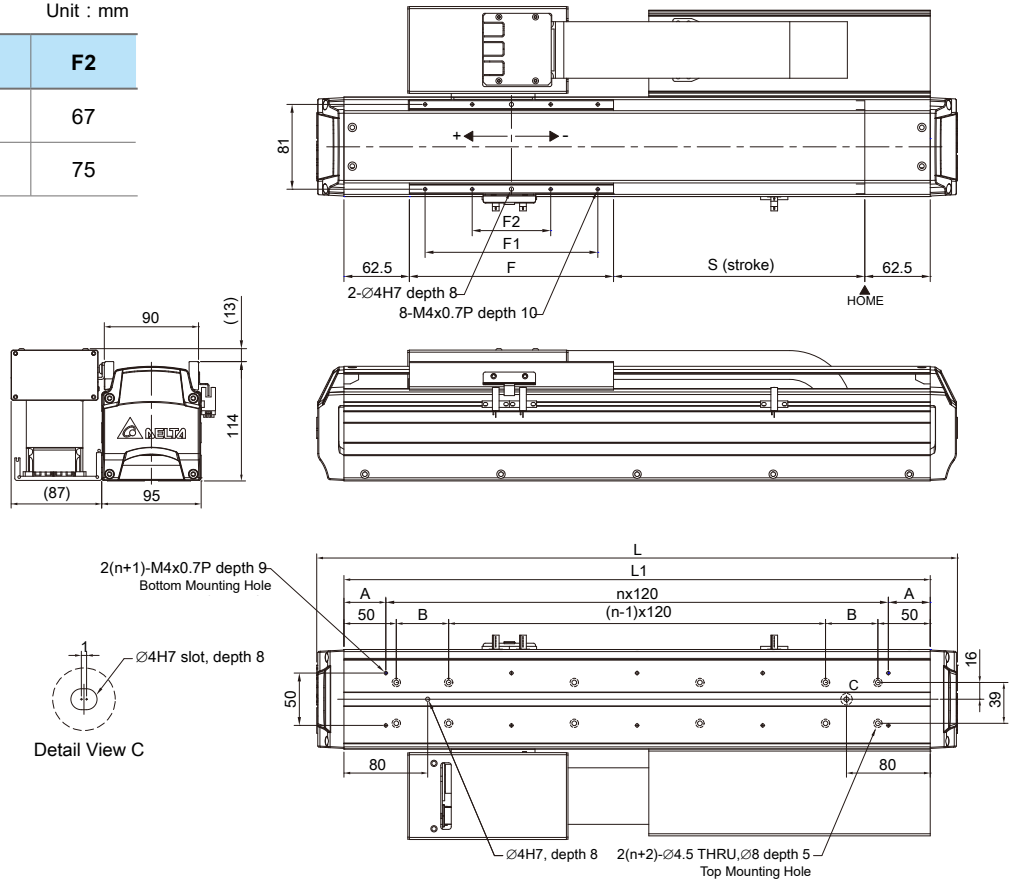

Stroke and base mounting dimensions

Unit: mm

LA-S4	Stroke, S	150	210	270	330	390	450	510	570	630	690	750	810	870	930	990
	Total Weight (kg)	11.2	11.9	12.6	13.3	13.9	14.6	15.3	15.9	16.6	17.3	18	18.7	19.4	20	20.7
LA-S5	Stroke, S	-	180	240	300	360	420	480	540	600	660	720	780	840	900	960
	Total Weight (kg)	-	12.2	12.8	13.6	14.3	14.9	15.6	16.3	16.9	17.6	18.3	19	19.7	20.4	21
Stage Total Length, L		492	552	612	672	732	792	852	912	972	1032	1092	1152	1212	1272	1332
L1		440	500	560	620	680	740	800	860	920	980	1040	1100	1160	1220	1280
A		40	10	40	10	40	10	40	10	40	10	40	10	40	10	40
B		50	20	50	20	50	20	50	20	50	20	50	20	50	20	50
n		3	4	4	5	5	6	6	7	7	8	8	9	9	10	10

LA-S6 / LA-S7 / LA-S8

ø25 Magnetic way/Effective stroke range: 100~1,300 mm

Slider dimensions Unit: mm

Models	Slider Total Length, F	F1	F2
LA-S6	185	165	85
LA-S7	225	205	85
LA-S8	285	265	145

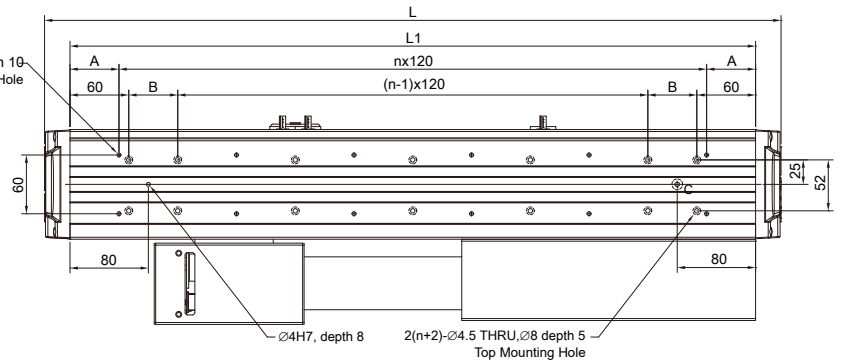
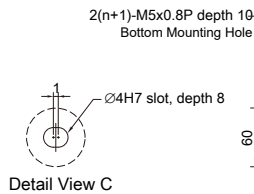
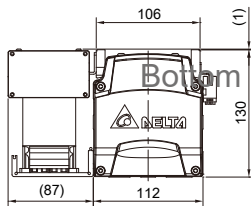
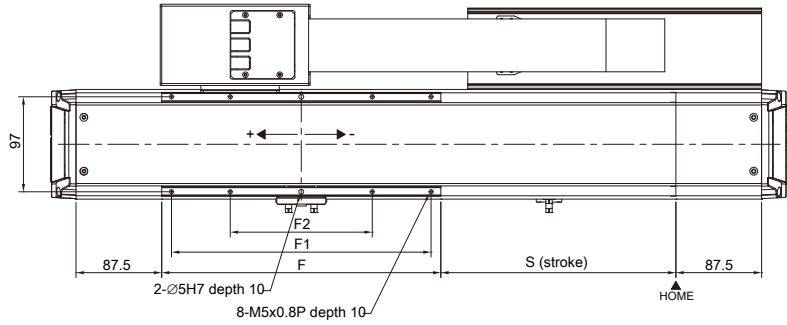

Stroke and base mounting dimensions

Unit: mm

LA-S6	Stroke, S	100	160	220	280	340	400	460	520	580	640	700	760	820	880	940	1000	1060	1120	1180	1240	1300
	Total Weight (kg)	13.6	14.5	15.5	16.5	17.4	18.4	19.3	20.3	21.3	22.2	23.2	24.1	25.1	26.1	27	27.9	28.9	29.9	30.8	31.8	32.8
LA-S7	Stroke, S	-	120	180	240	300	360	420	480	540	600	660	720	780	840	900	960	1020	1080	1140	1200	1260
	Total Weight (kg)	-	15.6	16.5	17.5	18.5	19.4	20.4	21.3	22.3	23.3	24.2	25.2	26.1	27.1	28.1	29	29.9	30.9	31.8	32.8	33.8
LA-S8	Stroke, S	-	-	120	180	240	300	360	420	480	540	600	660	720	780	840	900	960	1020	1080	1140	1200
	Total Weight (kg)	-	-	17.6	18.6	19.6	20.5	21.5	22.4	23.4	24.4	25.3	26.3	27.2	28.2	29.2	30.1	31.1	32	33	33.9	34.9
Stage Total Length, L		512	572	632	692	752	812	872	932	992	1052	1112	1172	1232	1292	1352	1412	1472	1532	1592	1652	1712
L1		460	520	580	640	700	760	820	880	940	1000	1060	1120	1180	1240	1300	1360	1420	1480	1540	1600	1660
A		50	20	50	20	50	20	50	20	50	20	50	20	50	20	50	20	50	20	50	20	50
B		50	20	50	20	50	20	50	20	50	20	50	20	50	20	50	20	50	20	50	20	50
n		3	4	4	5	5	6	6	7	7	8	8	9	9	10	10	11	11	12	12	13	13

LA-SA / LA-SB

ø32 Magnetic way/Effective stroke range: 140~2,060 mm

Slider dimensions

Unit : mm

Models	Slider Total Length, F	F1	F2
LA-SA	223	201	91
LA-SB	278	256	116

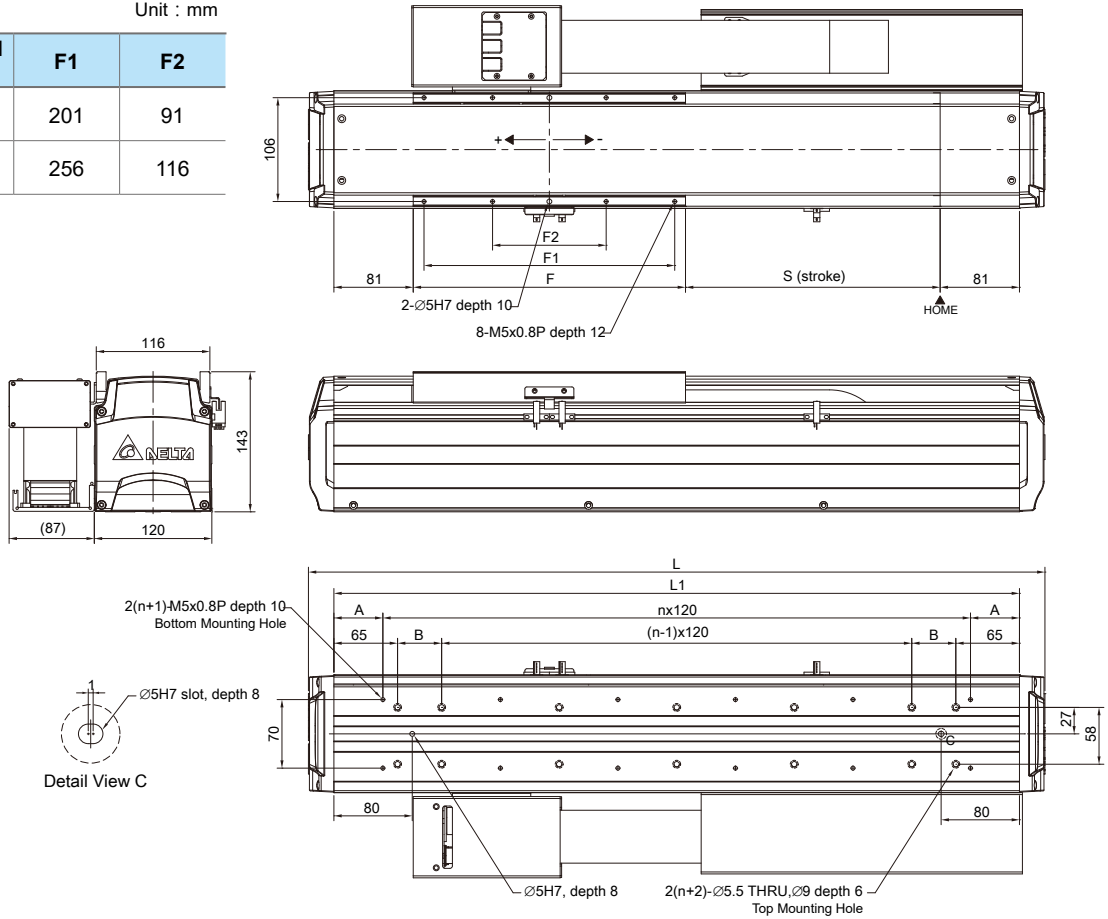

Stroke and base mounting dimensions

Unit: mm

LA-SA	Stroke, S	140	200	260	320	380	440	500	560	620	680	740	800	860	920	980	1040	1100
	Total Weight (kg)	16.3	17.5	18.7	19.9	21.2	22.4	23.7	24.9	26.1	27.4	28.6	29.4	30.7	31.9	33.2	34.4	35.7
LA-SB	Stroke, S	-	140	200	260	320	380	440	500	560	620	680	740	800	860	920	980	1040
	Total Weight (kg)	-	19.3	20.5	21.7	22.9	24.2	25.4	26.6	27.9	29.1	30.3	31.6	32.8	34	35.3	36.5	37.7
Stage Total Length, L		572	632	692	752	812	872	932	992	1052	1112	1172	1232	1292	1352	1412	1472	1532
L1		520	580	640	700	760	820	880	940	1000	1060	1120	1180	1240	1300	1360	1420	1480
A		20	50	20	50	20	50	20	50	20	50	20	50	20	50	20	50	20
B		15	45	15	45	15	45	15	45	15	45	15	45	15	45	15	45	15
n		4	4	5	5	6	6	7	7	8	8	9	9	10	10	11	11	12

LA-SA	Stroke, S	1160	1220	1280	1340	1400	1460	1520	1580	1640	1700	1760	1820	1880	1940	2000	2060
	Total Weight (kg)	37.2	38.4	39.7	40.9	42.1	43.3	44.6	45.8	47.1	48.3	49.5	50.7	51.9	53.2	54.5	55.7
LA-SB	Stroke, S	1100	1160	1220	1280	1340	1400	1460	1520	1580	1640	1700	1760	1820	1880	1940	2000
	Total Weight (kg)	38.9	40.2	41.4	42.6	43.9	45.1	46.3	47.5	48.8	50	51.2	52.5	53.7	54.9	56.1	57.4
Stage Total Length, L		1592	1652	1712	1772	1832	1892	1952	2012	2072	2132	2192	2252	2312	2372	2432	2492
L1		1540	1600	1660	1720	1780	1840	1900	1960	2020	2080	2140	2200	2260	2320	2380	2440
A		50	20	50	20	50	20	50	20	50	20	50	20	50	20	50	20
B		45	15	45	15	45	15	45	15	45	15	45	15	45	15	45	15
n		12	13	13	14	14	15	15	16	16	17	17	18	18	19	19	20

Ball Screw Driven Linear Stage LU Series



Ball-screw Design

Non-coupling structure enables the motor and screws to work more closely and reduces inertia ratio for fast response



Small and Short

Ball-screw design for shorter length of the module and saves mechanical costs



Various Options

Includes open-type and shielded designs, and normal and precise models for different applications



Easy to Install

Integrated module in one unit. Easy to install without extra mechanical parts; Saves development costs and resources

Product Introduction

Delta's Ball Screw Driven Linear Stage LU Series has its motor and screw in a patented non-coupling installation design. It features high stiffness, low inertia ratio, and fast response. The rated thrust is 181 to 905N, and the repeatability and setting time is better than one with coupling. It is also in a compact design, which saves space and is suitable for replacing traditional screw applications for higher stability and smaller space usage.

Product Advantages

- ▶ The whole series includes models with and without covers
- ▶ Provides the options of normal and precise grades
- ▶ The whole series uses steel structure to increase stiffness and avoid precision deviations
- ▶ Modular structure for direct installation on the equipment

Ordering Information

LU - 33 1 1 1 15 0 A P 0 S

Code	Product
LU	Ball Screw Driven Linear Stage

Code	Linear Motor Specifications
26	26mm
33	33mm
46	46mm

Code	Motor Frames
1	F40 (220V) (LU-26 & LU-33)
2	F60 (220V) (LU-46)

Code	Code Encoder
1	Increment Type, 20-bit

Code	Motor Output
1	100W (LU-26 & LU-33)
4	400W (LU-46)

Code	U-rail Length
XX	LU-26
Examples:	150 ~ 300 mm · a single pitch is 50 mm
15 = 150 mm	LU-33
69 = 600 mm	150 ~ 600 mm · a single pitch is 50 mm
94 = 940 mm	LA-46
	340 ~ 940 mm · a single pitch is 100 mm

Code	Motor Types
S	Standard
B	With Brakes

Code	Cover
0	Without Cover
1	With Cover

Code	Precision
N	Normal
P	Precise

Code	Block Type
A	1 Normal-type Block

Code	Lead
2	2 mm (LU-26)
6	6 mm (LU-26)
5	5 mm (LU-33)
0	10 mm (LU-33 & LU-46)
A	20 mm (LU-46)

Thrust Range

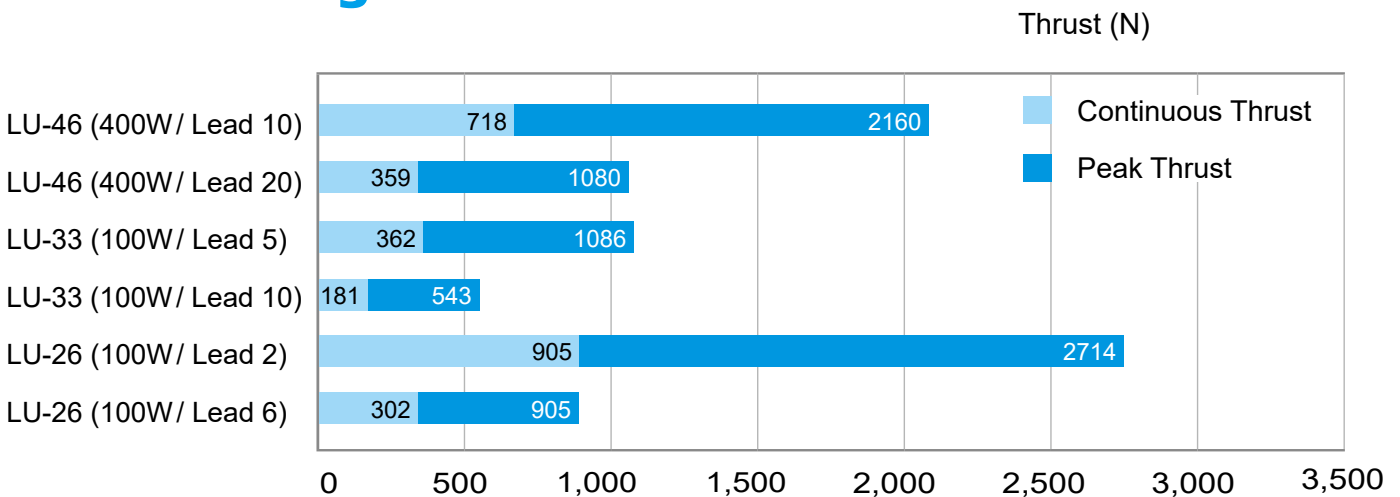

Stroke Range

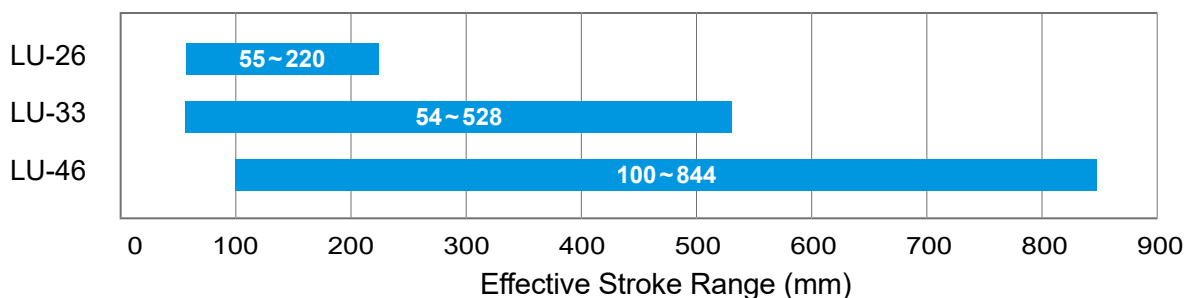

Servo Drive Selection Table

Models	Servo Drives	Motor Output	Lead (mm)	Rated Torque (N-m)	Peak Torque (N-m)
LU-26111 <input type="checkbox"/> <input type="checkbox"/> <input type="checkbox"/> <input type="checkbox"/> <input type="checkbox"/> <input type="checkbox"/> <input type="checkbox"/>	ASD-A3-0121- <input type="checkbox"/> ASD-A2-0121- <input type="checkbox"/>	100 W	2/6	0.32	0.96
LU-33111 <input type="checkbox"/> <input type="checkbox"/> <input type="checkbox"/> <input type="checkbox"/> <input type="checkbox"/> <input type="checkbox"/> <input type="checkbox"/>	ASD-B2-0121- <input type="checkbox"/>		5/10		
LU-46214 <input type="checkbox"/> <input type="checkbox"/> <input type="checkbox"/> <input type="checkbox"/> <input type="checkbox"/> <input type="checkbox"/> <input type="checkbox"/>	ASD-A3-0421- <input type="checkbox"/> ASD-A2-0421- <input type="checkbox"/> ASD-B2-0421- <input type="checkbox"/>	400 W	10/20	1.27	3.82

* For the servo drive with the code of ASDA-A3 / A2R, please refer to the model information of Delta's servo drive

Product Specifications

Stroke and Weight

Ball Screw Specifications		Maximum Stroke	Screw Overall Length	Screw Shaft Diameter	Weight (without Cover)	Weight (with Cover)
Models	Rail Length (mm)	(mm)	L (mm)	D (mm)	kg	kg
LU-26	150	70	191	8	1.4	1.48
	200	120	241	8	1.6	1.68
	250	170	291	8	1.8	1.88
	300	220	341	8	2.01	2.09
LU-33	150	54.5	194	12	2.17	2.36
	200	104.5	244	12	2.48	2.68
	300	204.5	344	12	3.06	3.26
	400	304.5	444	12	3.65	3.88
	500	404.5	544	12	4.35	4.59
	600	504.5	644	12	4.96	5.21
LU-46	340	208.2	399	15	9.25	9.85
	440	308.2	499	15	10.54	11.14
	540	408.2	599	15	11.84	12.44
	640	508.2	699	15	13.15	13.75
	740	608.2	799	15	14.55	15.15
	940	808.2	999	15	16.84	17.44

Loading Specifications

Loading capacity

Models	Lead (mm)	Linear Guideway		Ball Screw			
		Basic Dynamic Load Rating C (kN)	Basic Static Load Rating C ₀ (kN)	Basic Dynamic Load Rating C (kN)		Basic Static Load Rating C ₀ (kN)	
		A	A	Normal, N	Precise, P	Normal, N	Precise, P
LU-26	2	7.99	15.230	1.790	2.500	2.940	4.020
	6			0.880	1.180	1.180	1.670
LU-33	5	12.210	22.110	2.250	2.940	4.310	5.100
	10			2.160	2.840	3.720	4.510
LU-46	10	26.350	46.650	5.000	6.660	8.920	11.860
	20			3.720	5.000	6.370	8.530

* Note: A refers to block types

Static permissible moment

Models	Lead (mm)	Static Permissible Moment		
		M _P	M _Y	M _R
		Block Type	Block Type	Block Type
		A	A	A
LU-26	2	107.3	107.3	278.6
	6			
LU-33	5	156.6	156.6	462
	10			
LU-46	10	575	575	1397.9
	20			

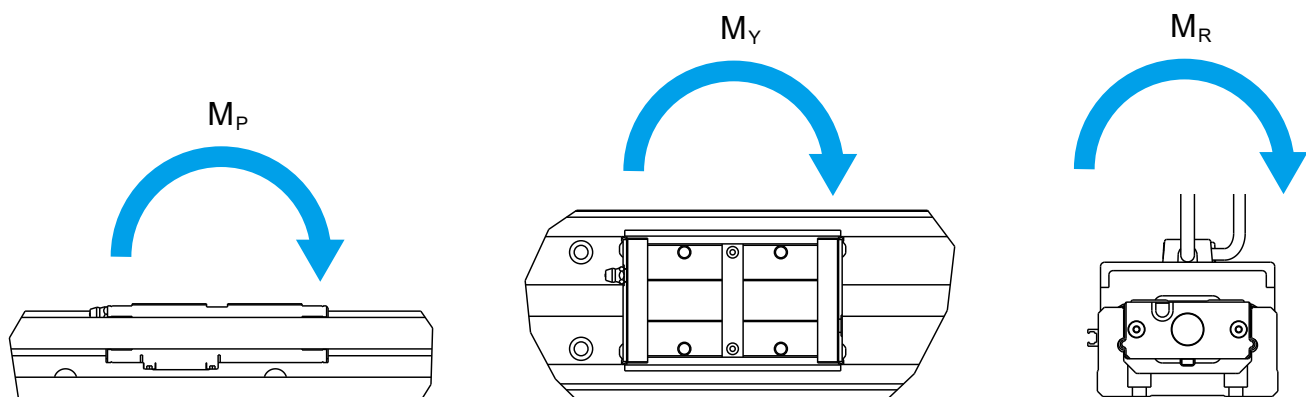

Precision

Unit : mm

Ball Screw Specifications		Repeatability		Positioning Precision		Running of Parallelism		Backlash	
Models	Rail Length	Normal Precise, N	Precise, P	Normal, N	Precise, P	Normal, N	Precise, P	Normal, N	Precise, P
LU-26	150	±0.01	±0.003	-	0.02	-	0.01	0.02	0.003
	200								
	250								
	300								
LU-33	150	±0.01	±0.003	-	0.02	-	0.01	0.02	0.003
	200								
	300								
	400				0.025		0.015		
	500								
600									
LU-46	340	±0.01	±0.003	-	0.025	-	0.015	0.02	0.003
	440								
	540								
	640				0.03		0.02		
	740								
	940				0.04		0.03		

Maximum Travel Speed

Ball Screw Specifications (mm)			Maximum Travel Speed (mm/s) / Maximum Motor RPM (rpm)				
Models	Ball Screw Lead	Rail Length	N	P			
LU-26	2	150	167 / 5000	167 / 5000			
		200					
		250					
		300					
LU-26	6	150	500 / 5000	500 / 5000			
		200					
		250					
		300					
LU-33	5	150	390 / 4680	417 / 5000			
		200					
		300					
		400					
	LU-33	10	500	790 / 4740	833 / 5000		
			600				
			340			650 / 3900	650 / 3900
			440				
540							
640							
LU-46	10	740	520 / 3120	740 / 4440			
		940					
		430 / 2580			600 / 3600		
		340					
		440			1050 / 3150	1480 / 4440	
	540						
	640						
	740						
	940						
	LU-46	20	1440 / 4320	840 / 2520	1200 / 3600		
940							

Product Dimensions

LU-26

Module Specifications		Maximum Stroke (mm)	Overall Length, L (mm)	E	n	E1	n1	F
Model	Rail Length, L1 (mm)	A	100W	mm	-	mm	-	mm
LU-26	150	70	278.6	35	2	35	-	80
	200	120	328.6	20	3	20	-	160
	250	170	378.6	45	3	45	-	160
	300	220	428.6	30	4	30	-	240

LU-26111 □ □ □ □ □ 0 □

(100W servo motor, without cover)

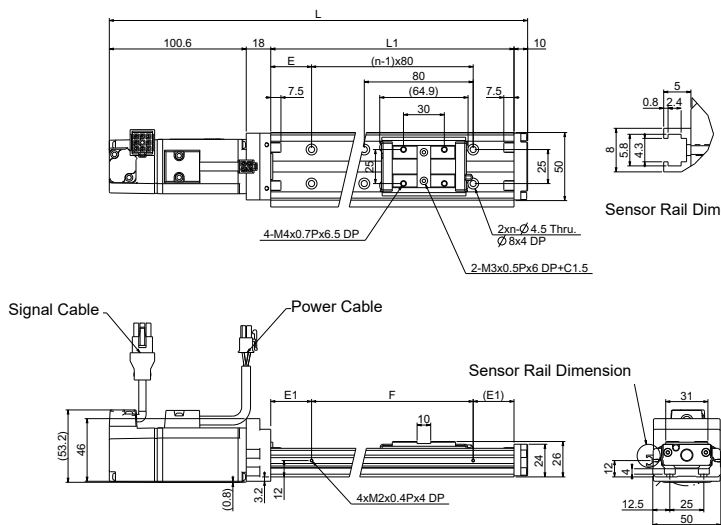

Carrier-Nut Type

A: Use one carrier nut with standard length

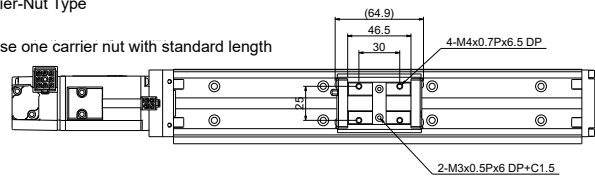

Sensor Rail Dimensions

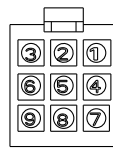

ENCODER CONNECTOR		
PIN No.	FUNCTION	COLOR
1	T+	WHT
2	---	---
3	---	---
4	T-	WHT/RED
5	---	---
6	---	---
7	DC+5V	BRN
8	GND	BLU
9	SHIELD	SHIELD



MOTOR CONNECTOR		
PIN No.	FUNCTION	COLOR
1	U	RED
2	V	WHT
3	W	BLK
4	GND	GRN / YEL

LU-26111 □ □ □ □ □ 1 □ (100W servo motor, with cover)

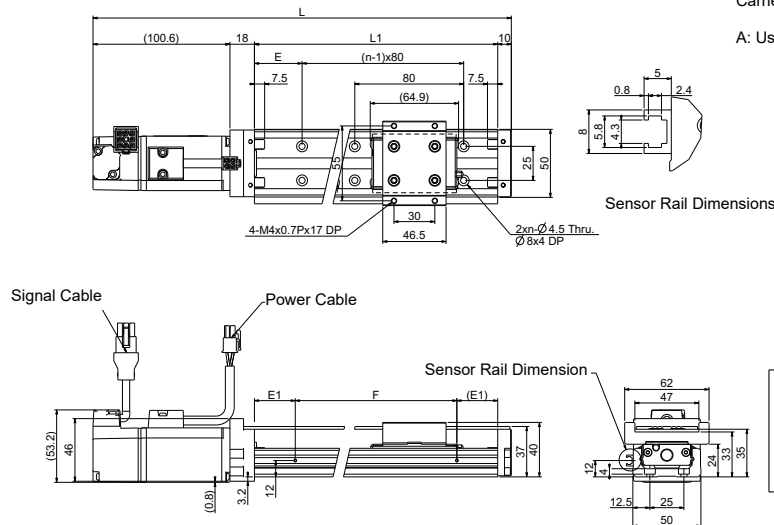

Carrier-Nut Type

A: Use one carrier nut with standard length



Sensor Rail Dimensions

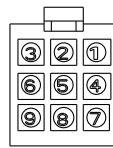

ENCODER CONNECTOR		
PIN No.	FUNCTION	COLOR
1	T+	WHT
2	---	---
3	---	---
4	T-	WHT/RED
5	---	---
6	---	---
7	DC+5V	BRN
8	GND	BLU
9	SHIELD	SHIELD



MOTOR CONNECTOR		
PIN No.	FUNCTION	COLOR
1	U	RED
2	V	WHT
3	W	BLK
4	GND	GRN / YEL

Product Dimensions

LU-33

Module Specifications		Maximum Stroke (mm)	Overall Length, L (mm)	E	n	E1	n1	F
Model	Rail Length, L1 (mm)	A	100W	mm	-	mm	-	mm
LU-33	150	54.5	282.5	25	2	25	2	100
	200	104.5	332.5	50	2	50	2	100
	300	204.5	432.5	50	3	50	2	200
	400	304.5	532.5	50	4	100	2	200
	500	404.5	632.5	50	5	50	3	200
	600	504.5	732.5	50	6	100	3	200

LU-33111 □□□□□ 0 □ (without cover)

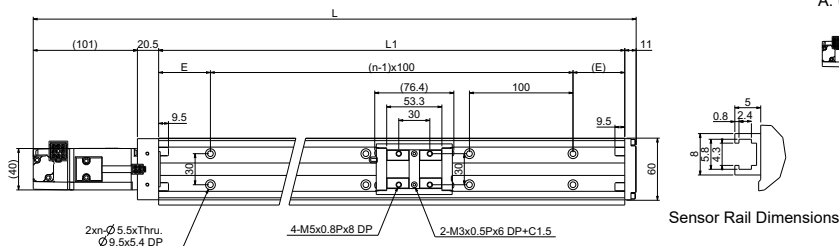

Carrier-Nut Type

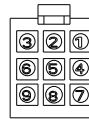
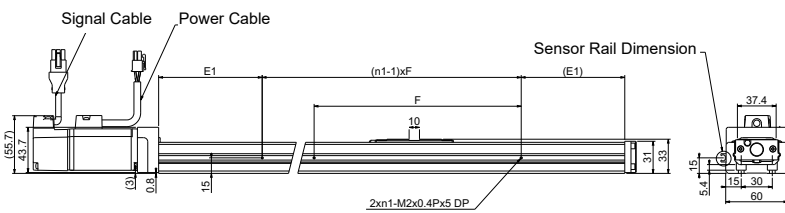
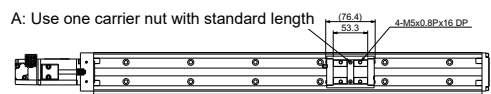

ENCODER CONNECTOR		
PIN No.	FUNCTION	COLOR
1	T+	WHT
2	---	---
3	---	---
4	T-	WHT/RED
5	---	---
6	---	---
7	DC+5V	BRN
8	GND	BLU
9	SHIELD	SHIELD



MOTOR CONNECTOR		
PIN No.	FUNCTION	COLOR
1	U	RED
2	V	WHT
3	W	BLK
4	GND	GRN / YEL

LU-33111 □□□□□ 1 □ (with cover)

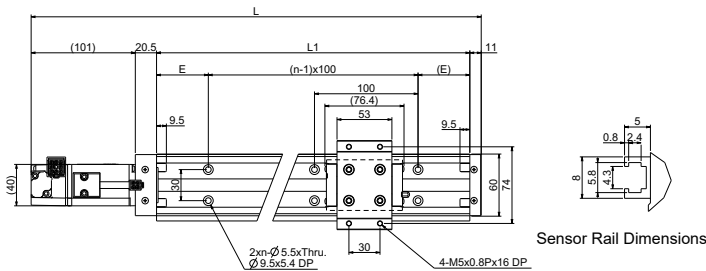

Carrier-Nut Type

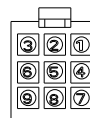
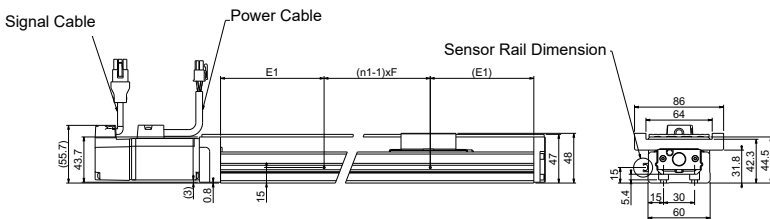
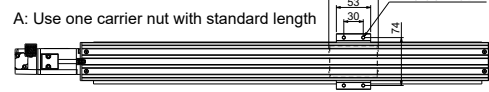

ENCODER CONNECTOR		
PIN No.	FUNCTION	COLOR
1	T+	WHT
2	---	---
3	---	---
4	T-	WHT/RED
5	---	---
6	---	---
7	DC+5V	BRN
8	GND	BLU
9	SHIELD	SHIELD



MOTOR CONNECTOR		
PIN No.	FUNCTION	COLOR
1	U	RED
2	V	WHT
3	W	BLK
4	GND	GRN / YEL

LU-46

Module Specifications		Maximum Stroke (mm)	Total Length, L (mm)	E	n	E1	n1	F
Models	Rail Length, L1 (mm)	A	400W	mm	-	mm	-	mm
LU-46	340	208.2	506.9	70	3	70	2	-
	440	308.2	606.9	70	4	20	3	-
	540	408.2	706.9	70	5	70	3	-
	640	508.2	806.9	70	6	20	4	-
	740	608.2	906.9	70	7	70	4	-
	940	808.2	1106.9	70	9	70	5	-

LU-46214 □□□□□ 0 □ (without cover)

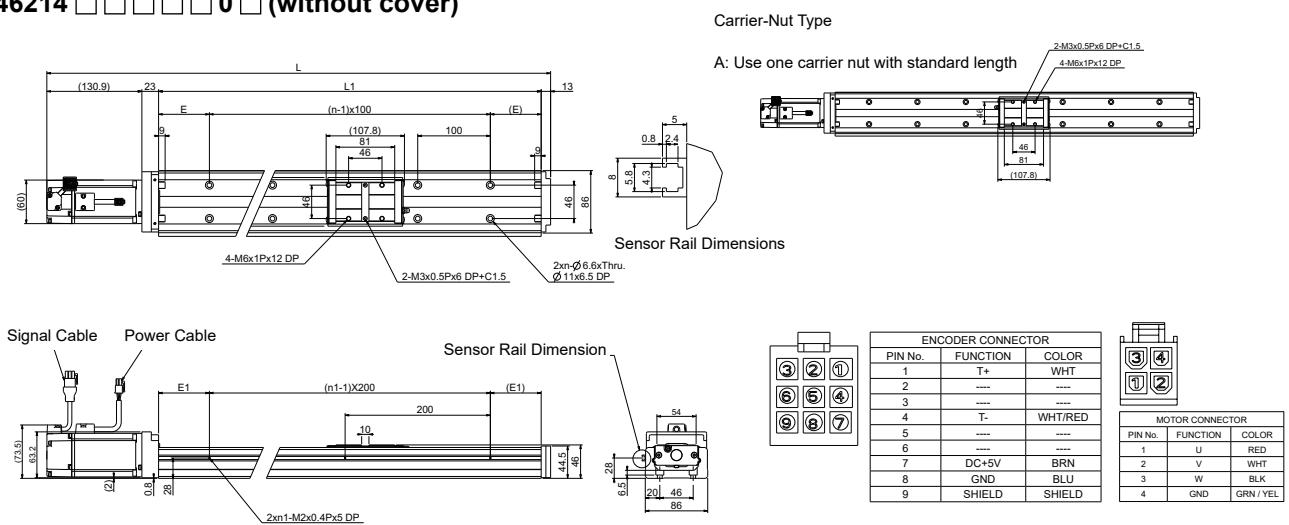

LU-46214 □□□□□ 1 □ (with cover)

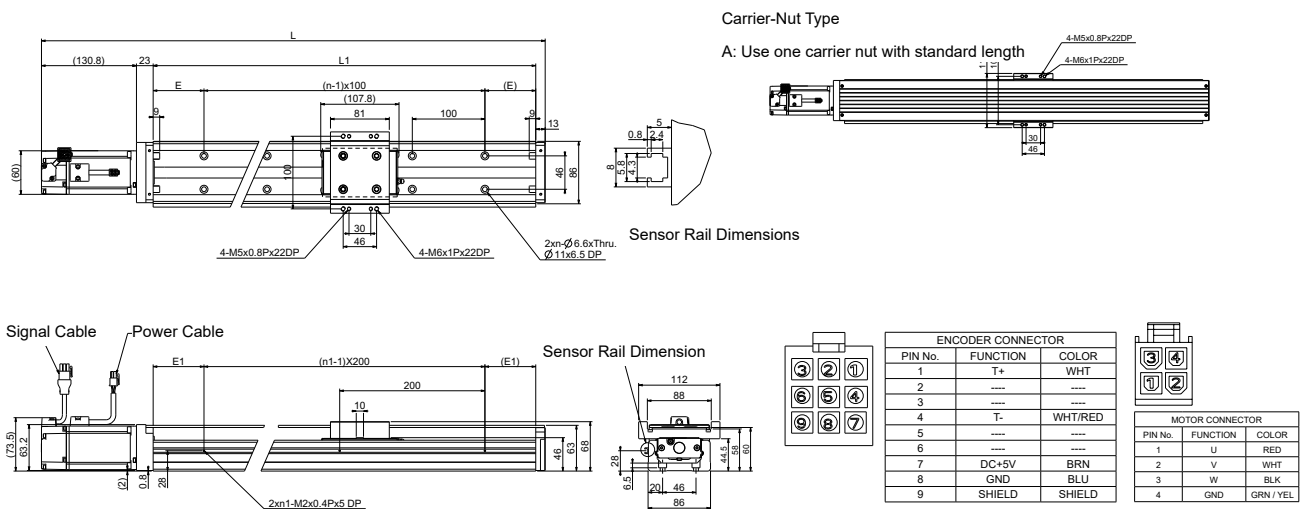

Recommended Sensor Models

Installation dimensions for detecting plate & mounting plates

Panasonic

GX-F12A / GX-F12B

Unit: mm

Models	a	b	c	d
LU-26	38.9	7.9	6.2	6.2
LU-33	44	1	9.2	10
LU-46	57	1	22.2	23

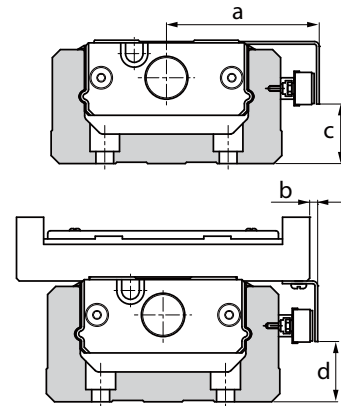

Omron

EE-SX671 / SX971

Unit: mm

Models	a	b	c	d	e	f	g	h
LU-26	46	15	2	2	58.5	27.5	10.5	10.5
LU-33	50.9	7.9	5	5	63.4	20.4	13.8	15
LU-46	63.9	7.9	18	18	76.4	20.4	26.5	28

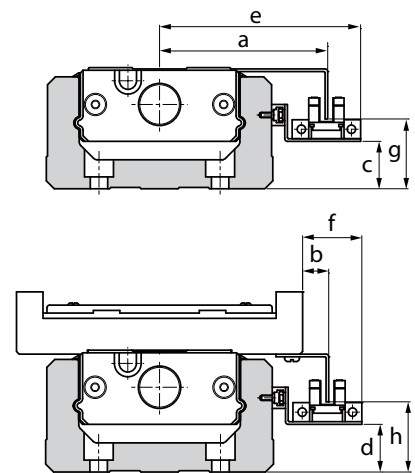

Omron

EE-SX671 / SX971

Unit: mm

Models	a	b	c	d	e	f	g	h
LU-26	43.7	12.7	1.8	1.8	50	19	10.8	10.8
LU-33	48.6	5.6	4.8	4.8	54.9	11.9	13.8	14
LU-46	61.6	5.6	17.8	17.8	67.9	11.9	26.8	28.1

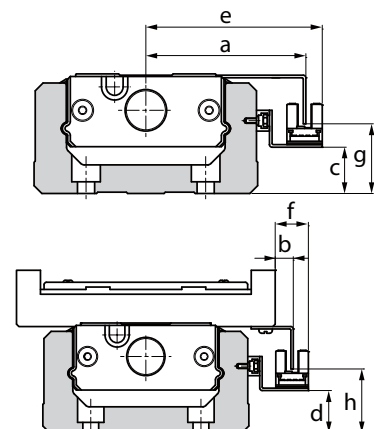

Optical Linear Encoders MSR-LEH Series

NEW



Multiple Resolutions

- ▶ Communication Type: 4nm
- ▶ Pulse-output Type: 1 μm 、 0.5 μm
(Coming Soon)



Explosion Proof

Capable of detecting missing pulse with Delta's servo drives. Pre-protects the equipment and avoids danger by being explosion proof



High Pollution Resistance

Special pattern design to increase oil and small-particle pollution resistance



Excellent Assembly Common Differences

Delta's integrated optoelectronics technology enables better assembly tolerance of the linear encoders

Product Introduction

Delta's Linear Encoder MSR-LEH Series is a high precision optical linear encoder features high pollution resistance, missing pulse detection, and it is explosion proof (with Delta's servo drive). High resolution of 4nm, suitable for high-speed and high-precision applications, it is commonly used for linear motor position feedback or installed outside rotary motors for extra precision.

Product Advantages

- ▶ Reflective optical inspection design. smaller encoder read heads
- ▶ Includes communication and pulse-output types for different requirements of the servo drives
- ▶ Employs LED indicators at the encoder read heads, clearly shows the current installation status
- ▶ Satisfies high-resolution (4nm) and high-speed (10m/s) working environments

* Note: For more details of the linear encoders, refer to Delta's official website

Ordering Information

Optical Read Head

MSR - LEH - SDE 4N 3 Q5 S1

Code	Series
MSR	Motion Control Sensors

Code	Product
LEH	Linear Encoder Read Head

Code	Application Types
SDE	Increment Type

Code	Type
S1	Standard Product

Code	Switch Type
Q5	0.5m Fast Switch

Code	Output Signal
3	Delta's Communication Protocol

Code	Resolution
4N	4nm

Optical Ruler

MSR - LES - SLE 10000 S0

Code	Series
MSR	Motion Control Sensors

Code	產品
LES	Linear Optical Ruler

Code	Material
SLE	Stainless Steel

Code	Type
S0	Standard Products

Code	Length
10000	10 m

Product Specifications

Optical Read Head

Resolution	Communication Type	4 nm
Dimensions (H x W x L)		36.4 × 15.2 × 14.15 mm
Weight (Read Head + Cable)		35 g
Temperature	Operating Temperature (°C)	0 ~ +70
	Storage Temperature (°C)	-20 °C ~ +70
Humidity	Operating Humidity (RH)	95 % (Non-condensing)
	Storage Humidity (RH)	95 % (Non-condensing)
Linear Velocity		10 m/s
Rating		IP40
Wiring		Fast Switch
Wiring Length (m)		0.5 m

Optical Ruler

Dimensions (H x W)		0.4 × 8 mm (Includes backing adhesive 0.2 mm)
Precision (20 °C)		±5 μm/m
Length		10 m
Materials		Stainless Steel with backing adhesive
Weight		12.3 g/m
Heat Expansion Constant (20 °C)		11 μm/m/°C
Reference Mark (Z) Gap		51.2 mm
Temperature	Operating Temperature (°C)	0 ~ +70
	Storage Temperature (°C)	-20 °C ~ +70
Humidity	Operating Humidity (RH)	95 % (Non-condensing)
	Storage Humidity (RH)	95 % (Non-condensing)

Product Dimensions

Read head and optical ruler

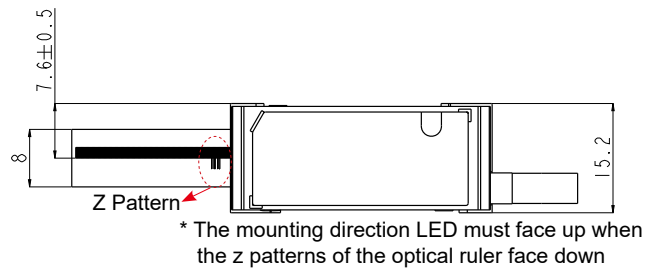
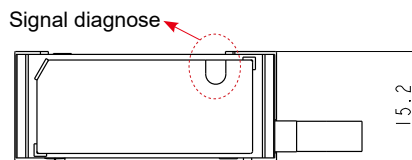
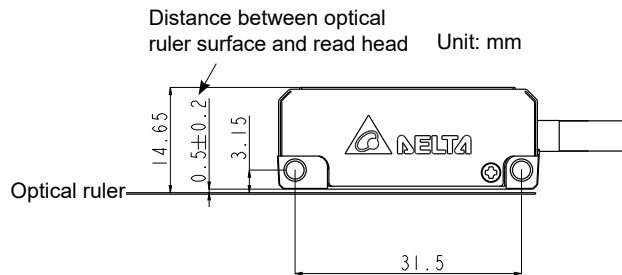
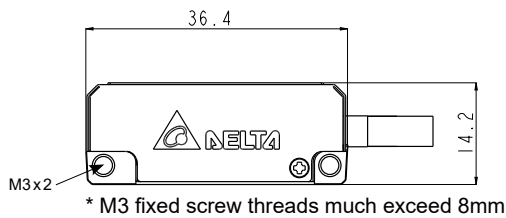

Read head tolerance common differences

Common Differences of the Read Head and the Ruler	
Y	±0.5mm
Z	±0.2mm
θx	±1.5 Degree
θy	±1.5 Degree
θz	±1.0 Degree

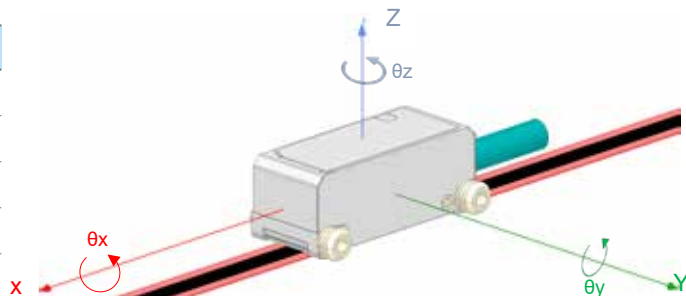

Wiring, communication type

Functions	Signals	Cable Colors
Power	V+	Brown
	GND	Blue
Output Signals	T+	White
	T-	White / Red

Delta Servo Drive Introduction

Delta ASDA-A3 Series Servo Drive



Ordering Information

ASD - A3 - 04 21 - L

Code	Product
ASD	AC Servo Drive

Code	Series
A3	A3 Series



Code	Rated Input Power
01	100W
02	200W
04	400W
07	750W
10	1kW
15	1.5kW
20	2kW
30	3kW

Code	Types
L	Please see the table below

Code	Input Voltage and Phase
21	220V Single / Third Phase
23	220V Third Phase

Code	PT Mode Pulse Input	PR Mode	RS-485	CANopen	DMCNET	EtherCAT	Closed-loop Control	Analog Voltage Control	Electronic Cam	STO
L	○	○	○	X	X	X	○	○	X	X
M	○	○	○	○	X	X	○	○	○	○
F	X	○	X	X	○	X	○	X	○	X
E	X	○	X	X	X	○	○	X	○	○

Product Specifications

ASDA-A3		100 W	200 W	400 W	750 W	1 kW	1.5 kW	2 kW	3 kW	
		01	02	04	07	10	15	20	30	
Power supply	Phase / Voltage	Single-phase / three-phase 220 VAC						Three-phase 220 VAC		
	Permissible Voltage Range	Single-phase / three-phase 200~230 VAC, -15%~10%						Three-phase 200~230 VAC, -15%~10%		
	Input Current(3PH) (Units: Arms)	0.67	1.34	2.67	5.01	6.68	10.02	13.36	20.05	
	Input Current(1PH) (Units: Arms)	1.16	2.31	4.63	8.68	11.57	17.36	-	-	
	Continuous Output Current (Units: Arms)	0.9	1.55	2.65	5.1	7.3	12.6	13.4	19.4	
Instantaneous Maximum Output Current (Units: Arms)		3.54	7.07	10.61	21.21	24.75	35.36	53.03	70.71	
Cooling System		Natural Air Circulation				Fan Cooling				
Drive Resolution		24-bit (1677216 p/rev)								
Control of Main Circuit		SVPWM Control								
Tuning Modes		Auto / Manual								
Regenerative Resistor		None			Built-in					
Position Control Mode	Pulse Type (Only for Non-DMCNET mode)	Pulse + Direction, A phase + B + CW pulse								
	Max. Input Pulse Frequency (Only for Non-DMCNET mode)	Pulse + Direction: 4Mpps ; CCW pulse + CW pulse: 4Mpps ; A phase + B phase: Single phase 4Mpps ; Max. 200Kpps (Open collector)pps								
	Command Source	External pulse train (PT mode) (Only for Non-DMCNET mode) / Internal parameters (PR mode)								
	Smoothing Strategy	Low-pass and P-curve filter								
	Electronic Gear	Electronic gear N/M multiple N: 1~536870911, M: 1~2147483647 (1/4< N/M < 262144)								
	Torque Limit Operation	Set by parameters								
	Feed Forward Compensation	Set by parameters								
Speed Control Mode	Analog Input Command (Only for Non-DMCNET mode)	Voltage Range	0 ~ ±10 V _{DC}							
		Resolution	15-bit							
		Input Resistance	1MΩ							
		Time Constant	25 μs							
	Speed Control Range **	1 : 6000								
	Command Source	External analog signal (Only for Non-DMCNET mode) / Internal parameters								
	Smoothing Strategy	Low-pass and S-curve filter								
	Torque Limit Operation	Set by parameters or analog input (Only for Non-DMCNET mode)								
	Frequency Response Characteristic	Maximum 3.1kHz								
	Speed Accuracy ²	0.01% or less at 0 to 100% load fluctuation								
0.01% or less at ±10% power fluctuation										
0.01% or less at 0°C to 50°C ambient temperature fluctuation										
Torque Control Mode	Analog Input Command (Only for Non-DMCNET mode)	Voltage Range	0 ~ ±10 V _{DC}							
		Input Resistance	1MΩ							
		Time Constant	25 μs							
		Command Source	External analog signal (Only for Non-DMCNET mode) / Internal parameters							
	Smoothing Strategy	Low-pass filter								
Speed Limit	Set by parameters or analog input (Only for Non-DMCNET mode)									
Analog Monitor Output		Monitor signal can set by parameters (Output voltage range: ±8V)								
Digital Inputs / Outputs	Inputs	Servo on, Reset, Gain switching, Pulse clear, Zero speed CLAMP, Command input reverse control, Command triggered, Speed/Torque limit enabled, Position command selection, Motor stop, Speed position selection, Position / Speed mode switching, Speed / Torque mode switching, Torque / Position mode switching, PT / PR command switching, Emergency stop, Forward / Reverse inhibit limit, Reference "Home" sensor, Forward / Reverse operation torque limit, Move to "Home", Electronic Cam (E-Cam), Forward / Reverse JOG input, Event trigger PR command, Electronic gear ratio (Numerator) selection and Pulse inhibit input								
	Outputs	* Please note that the above digital signals and inputs are available only for Non-DMCNET mode. In DMCNET mode, it is recommended to write digital inputs into the servo drives through DMCNET communication, and the digital inputs should be used for Emergency Stop, Forward / Reverse Inhibit limit and Reference "Home" sensor only. Encoder signal output (A, B, Z Line Driver and Z Open Collector) Servo ready, Servo on, At Zero speed, At Speed reached, At Positioning completed, At Torques limit, Servo alarm (Servo fault) activated, Electromagnetic brake control, Homing completed, Output overload warning, Servo warning activated, Position command overflow, Forward / Reverse software limit, Internal position command completed, Capture operation completed output., Motion control completed output., Master position of E-Cam (Electronic Cam)								
Protective Functions		Overcurrent, Overvoltage, Undervoltage, Motor overheated, Regeneration error, Overload, Overspeed, Abnormal pulse control command, Excessive deviation, Encoder error, Adjustment error, Emergency stop activated, Reverse/ Forward limit switch error, Position excessive deviation of full-close control loop, Serial communication error, Input power phase loss, Serial communication time out, short circuit protection of U, V, W, and CN1, CN2, CN3 terminals								
Communication Interface		RS-485 / CANopen / USB								
Environment	Installation Site	Indoor environment (free of direct sunlight), no corrosive liquid and gas (free of oil mist, flammable gas, or dust)								
	Altitude	Altitude 2000m or lower above sea level								
	Atmospheric Pressure	86kPa ~ 106kPa								
	Operating Temperature	0°C ~ 55°C (If operating temperature is above 45°C, forced cooling will be required)								
	Storage Temperature	-20 °C ~ 65 °C								
	Humidity	0 ~ 90% RH (non-condensing)								
	Vibration	9.80665 m/s ² (1G) less than 20Hz, 5.88 m/s ² (0.6G) 20 to 50Hz								
	IP Rating	IP20								
Power System	TN System ^{3,4}									
Approvals		IEC/EN 61800-5-1 · UL 508C						 		

Note: *1. When it is with the rated load, the speed ratio is: the minimum speed (smooth operation) / rated speed.

*2. When the command is the rated speed, the velocity correction ratio is: (free run speed - full load speed) / rated speed

*3. TN system: The neutral point of the power system connects to the ground directly. The exposed metal components connect to the ground via the protective earth conductor.





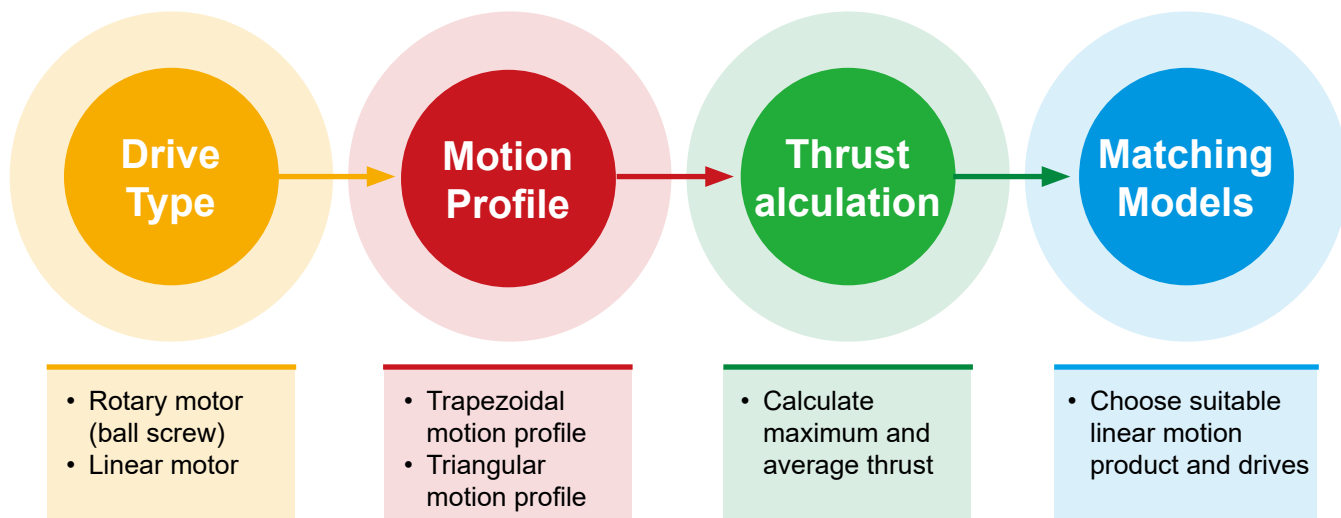



*4. Use a single-phase three-wire power systems for models of single-phase power

Model Selection

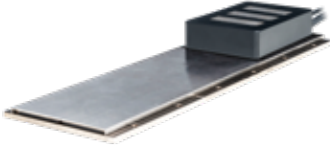

Drive Type

Delta's Linear Motion Products

Rotary Motor (Ball Screw)	Linear Motors	
		
		
		

Motion Curves

Based on the motion profile information, calculation data includes, 1. Moving speed; 2. Moving time; 3. Moving distance (The calculation only requires two of the above data)

Trapezoidal motion profile

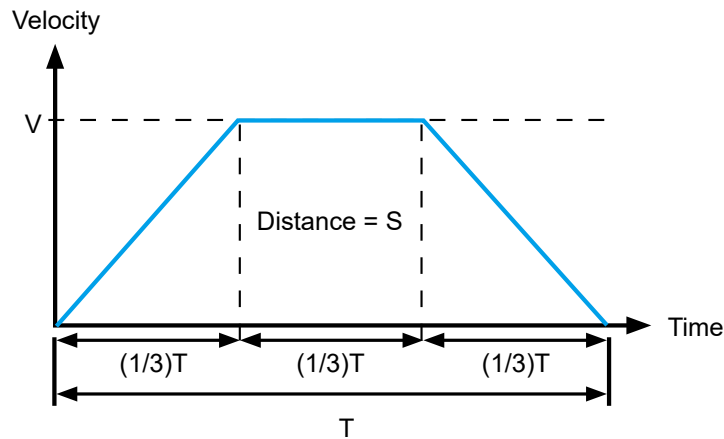

Known \ Obtained	Stroke, S (m) Time, T (sec)	Velocity, V (m/sec) Time, T (sec)	Acceleration, A (m/sec ²) Time, T (sec)	Acceleration, A (m/sec ²) Velocity, V (m/sec)
Stroke, S (m)		$S = \left(\frac{2}{3}\right) \times V \times T$	$S = (1/4.5) \times A \times T^2$	$S = 2 \times (V^2/A)$
Velocity, V (m/s)	$V = 1.5 \times (S / T)$		$V = (A \times T) / 3$	$V = \sqrt{(A \times S)/2}$
Acceleration, A (m/sec ²)	$A = 4.5 \times (S / T^2)$	$A = 3 \times (V / T)$		$A = 2 \times (V^2 / S)$

Triangular motion profile

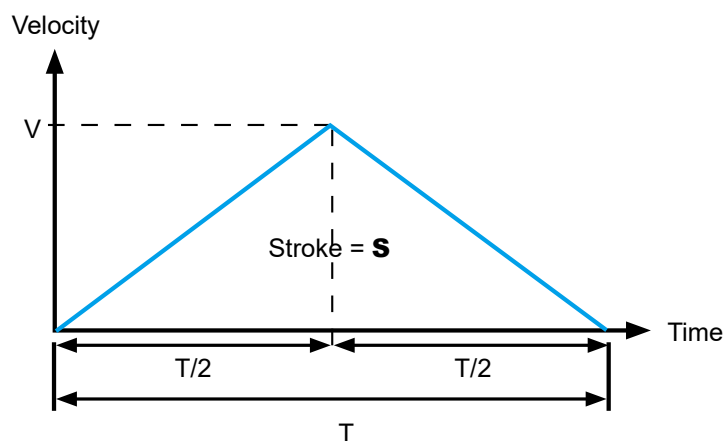

Known \ Obtained	Stroke, S (m) Time, T (sec)	Velocity, V (m/sec) Time, T (sec)	Acceleration, A (m/sec ²) Time, T (sec)	Acceleration, A (m/sec ²) Velocity, V (m/sec)
Stroke, S (m)		$S = (1/2) \times V \times T$	$S = (1/4) \times A \times T^2$	$S = V^2 / A$
Velocity, V (m/s)	$V = 2 \times (S / T)$		$V = (A \times T) / 2$	$V = \sqrt{A \times S}$
Acceleration, A (m/sec ²)	$A = 4 \times (S / T^2)$	$A = 2 \times (V / T)$		$A = V^2 / S$

Thrust Calculation

Formula

Formula	
Required thrust for acceleration section	$F_1 = F_2 + m \times a$
Required thrust for constant velocity section	$F_2 = \mu \times m \times g$
Required thrust for deceleration section	$F_3 = m \times a - F_2$
RMS Thrust (rms)	$F_{rms} = \sqrt{\left(\frac{F_1^2 \times t_1 + F_2^2 \times t_2 + F_3^2 \times t_3 + F_4^2 \times t_4}{t_1 + t_2 + t_3 + t_4} \right)}$
<p>μ : coefficient of sliding friction (eg. coefficient of friction of bearings, linear guideways)</p> <p>m : moving mass and external payload</p>	<p>g: 9.81 m/s²</p> <p>a: acceleration, m/s²</p>

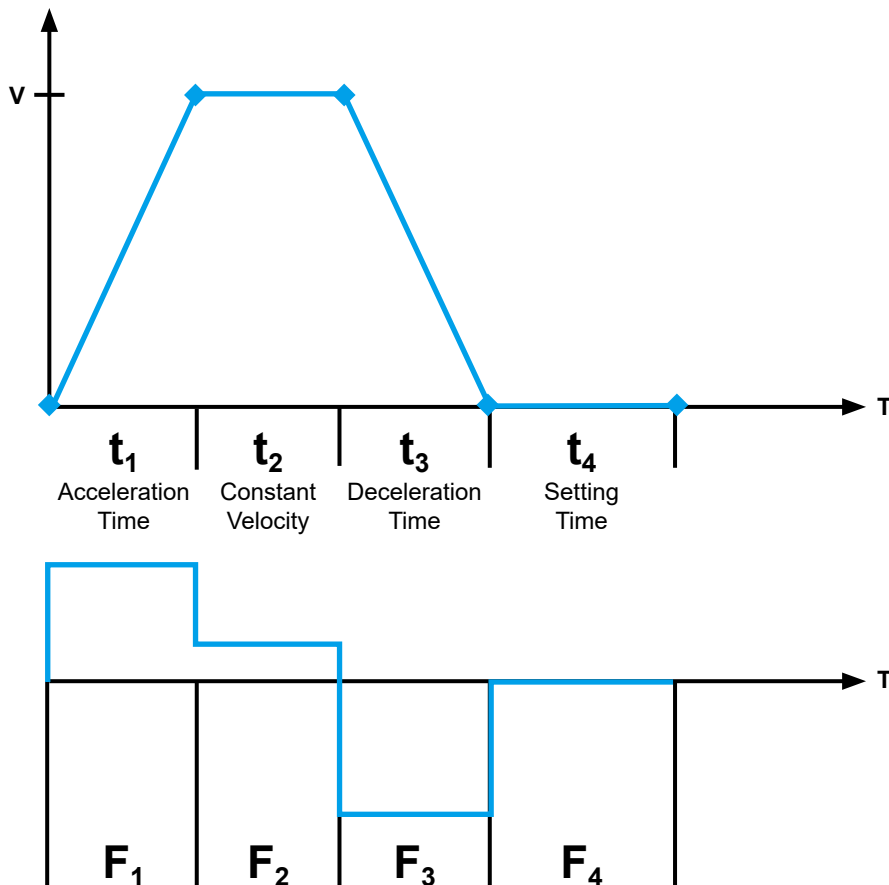

Calculation example 1 (ball screw driven)

Calculation Process 1

- 1 Take LU-33111300AP0S as an example, the motion profile and requirement include:

Total Mass, m	30 kg
Total Move Distance, S	300 mm
Max. Linear Velocity, V	300 mm/s
$t_1 = t_3$	0.2 sec
$t_2 = t_4$	0.8 sec
$t_1 + t_2 + t_3 + t_4 = t$	2 sec
Coefficient of Sliding Friction, μ	0.01
Acceleration of Gravity, g	9.8 m/s ²
Ball Screw Lead, L	0.01 m
Starting Torque, T_0	0.12 N-m
Torque at Driven Load, I_m	$0.37 \times 10^{-5} \text{kg-m}^2$
Motor Inertia, I_s	$0.55 \times 10^{-5} \text{kg-m}^2$
Motor Rated Torque	0.32 N-m
Screw Efficiency, η	0.9

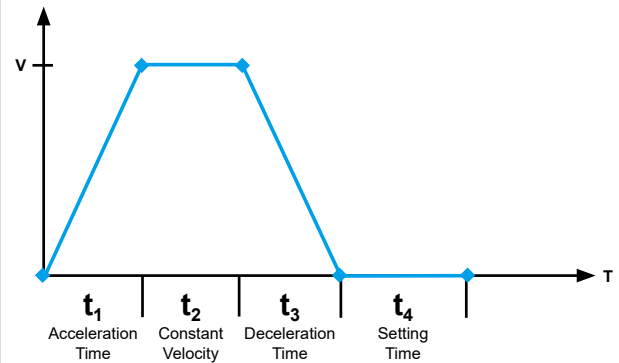

- 2 Calculates the required torque for the constant velocity section:

$$T_0 = T_0 + \mu mg \times \left(\frac{L}{2\pi \times 0.9}\right) = 0.12 + 0.01 \times 30 \times 9.8 \times \left(\frac{0.01}{2\pi \times 0.9}\right) \approx 0.13 \text{ N-m}$$

- 3 Calculates the acceleration section torque T (max. torque)

$$\text{Load Inertia } I_L = m \times \left(\frac{L}{2\pi}\right)^2 = 30 \times \left(\frac{0.01}{2\pi}\right)^2 \approx 7.6 \times 10^{-5} \text{ kg-m}^2$$

$$\text{Max. Rotational Speed } N = V \times 60/L = 1800 \text{ min}^{-1}$$

$$\text{Angular Acceleration } \omega = \frac{2\pi \times N}{60 \times t} = \frac{2\pi \times 1800}{60 \times 0.2} \approx 942$$

$$T_a = (I_m + I_s + I_L) \times \omega = (0.37 + 0.55 + 7.6) \times 10^{-5} \times 942 \approx 0.08 \text{ N-m}$$

$$T_a + T_s = 0.08 + 0.13 \approx 0.21 \text{ N-m}$$

Calculates Process 2

4	<p>Calculates RMS torque</p> $T_{rms} = \sqrt{\left(\frac{T^2 \times t_1 + (T - 2 \times T_s)^2 \times t_3 + T_s^2 \times t_2}{t}\right)} \cong 0.11 \text{ N-m}$
5	<p>Checks whether the RMS torque is less than the motor rated torque</p> <p>$T_{rms} \cong 0.11 < \text{Motor Rated Torque } 0.32 \text{ N-m} \rightarrow \text{OK}$</p> <p>Checks whether the max. torque T is less than the motor rated torque</p> <p>Generally, the safety factor is considered in the calculation of maximum torque</p> <p>Safety Factor k: general safety factor is 1.2 ~ 1.3</p> <p>$T \times k = 0.21 \times 1.3 = 0.27 \text{ N-m}$</p> <p>The max. torque 0.27 N-m < Motor Rated Torque 0.32 N-m $\rightarrow \text{OK}$</p>
6	<p>If the required torque is found to be larger than the motor rated torque, the size of the linear stage should be re-evaluated and then select the LU models with larger motor power</p>

Module Specifications		Ball Screw Moment of Inertia	Motor Inertia	Motor Power
Models	Rail Length (mm)	$\times 10^{-4} \text{ kg.m}^2$	$\times 10^{-4} \text{ kg.m}^2$	W
LU-26	150	0.0060	0.0206	50
	200	0.0076		
	250	0.0092	0.037	100
	300	0.0108		
LU-33	150	0.0310	0.037	100
	200	0.0390		
	300	0.0550		
	400	0.0710		
	500	0.0869		
	600	0.1029		
LU-46	340	0.1557	0.277	400
	440	0.1947		
	540	0.2337		
	640	0.2727		
	740	0.3117		
	940	0.3898		

Calculation example 2 (Linear motor driven)

Calculation Process	
<p>1 Given motion profile:</p> <p>Applied in pick-and-place machines (horizontal movement)</p> <p>Total mass, m: 10 kg</p> <p>Total move distance, S: 300 mm</p> <p>$t_1 = t_2 = t_3 = t_4 = 0.1$ sec</p> <p>$T = t_1 + t_2 + t_3 = 0.3$</p> <p>$\mu$: Coefficient of Sliding Friction = 0.005</p> <p>g: 9.81 m/s²</p>	<p>The graph shows a velocity-time profile for a linear motor. The vertical axis represents velocity (v) and the horizontal axis represents time (T). The profile is a trapezoid with four distinct phases: t_1 (Acceleration Time), t_2 (Constant Velocity), t_3 (Deceleration Time), and t_4 (Setting Time). The velocity starts at zero, increases linearly during t_1, remains constant during t_2, decreases linearly during t_3, and remains at zero during t_4.</p>
<p>2 Calculates the maximum thrust:</p> <p>$S = 0.3 \text{ m} = (2/3) \times V \times T = (2/3) \times V \times 0.3 \rightarrow V = 1.5 \text{ m/s}$</p> <p>$a = V/t_1 = 1.5/0.1 = 15 \text{ m/s}^2$</p> <p>Required thrust for acceleration section = $F_1 = F_2 + m \times a = 0.49 + 10 \times 15 = 150.49 \text{ N}$</p> <p>Required thrust for constant velocity section = $F_2 = \mu \times m \times g = 0.005 \times 10 \times 9.81 = 0.49 \text{ N}$</p> <p>Required thrust for deceleration section = $F_3 = m \times a - F_2 = 10 \times 15 - 0.49 = 149.51 \text{ N}$</p> <p>Required thrust for setting section = $F_4 = 0 \text{ N}$</p> <p>$\rightarrow F_{\max} = F_1 = 150.49$</p>	
<p>3 Calculates the RMS thrust:</p> $F_{\text{rms}} = \sqrt{\left(\frac{F_1^2 \times t_1 + F_2^2 \times t_2 + F_3^2 \times t_3 + F_4^2 \times t_4}{t_1 + t_2 + t_3 + t_4} \right)} = 106 \text{ N}$	
<p>4 Safety factor: general safety factor is 1.2 ~ 1.3</p> <p>$F_{\max} = 150.49 \times \text{Safety Factor} = 150.49 \times 1.2 = 180.59 \text{ N}$</p> <p>$F_{\text{rms}} = 106 \times \text{Safety Factor} = 106 \times 1.2 = 127.2 \text{ N}$</p>	
<p>5 Refer to LA-S thrust range, rated thrust $> F_{\max}$ and F_{rms}</p> <p>Suggested linear stage model: LA-SB</p> <p>Refer to LA-S Series and Servo Drive Selection Table: 750 W</p>	

Linear Stage Request Form

Date:

Company Name:	
Product Required	Specification Requirements
Industry of the Company	
Equipment Applications	
Max. Velocity	(m/s)
Max. Acceleration / Deceleration	(m/s ²)
Stroke	(mm)
Load	(kg)
Repeatability	± (μm)
Multiple Rotors in Single Axis	<input type="checkbox"/> Yes (pcs/axis) <input type="checkbox"/> No
Vertical Applications	<input type="checkbox"/> Yes <input type="checkbox"/> No
Stage Mounting Direction	<input type="checkbox"/> Horizontal <input type="checkbox"/> Lateral <input type="checkbox"/> Upside Down
Total Amount Required	
Drive Voltage	
Request for External Electricity Regeneration (to be confirmed with electrical control personnel)	<input type="checkbox"/> Yes <input type="checkbox"/> No

Speed Curves

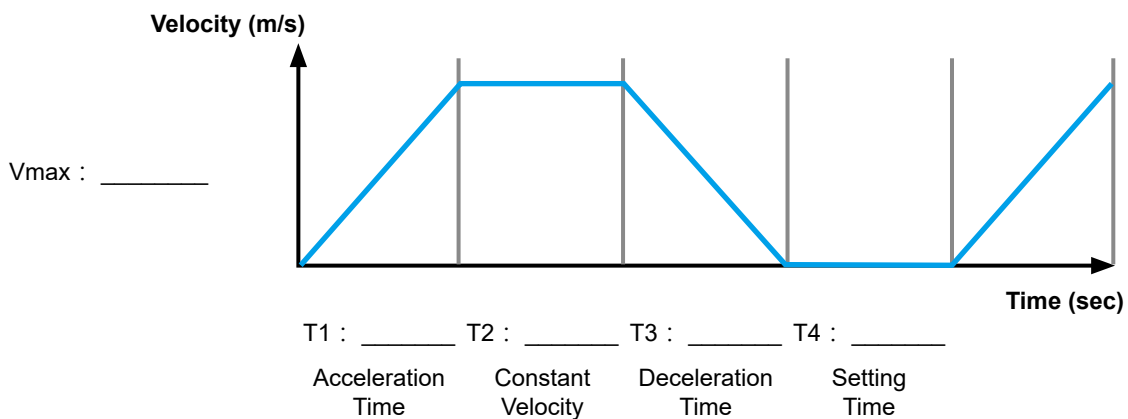

Special Requirements and Notes (e.g. high temperature or clean room operation or others)

Global Operations

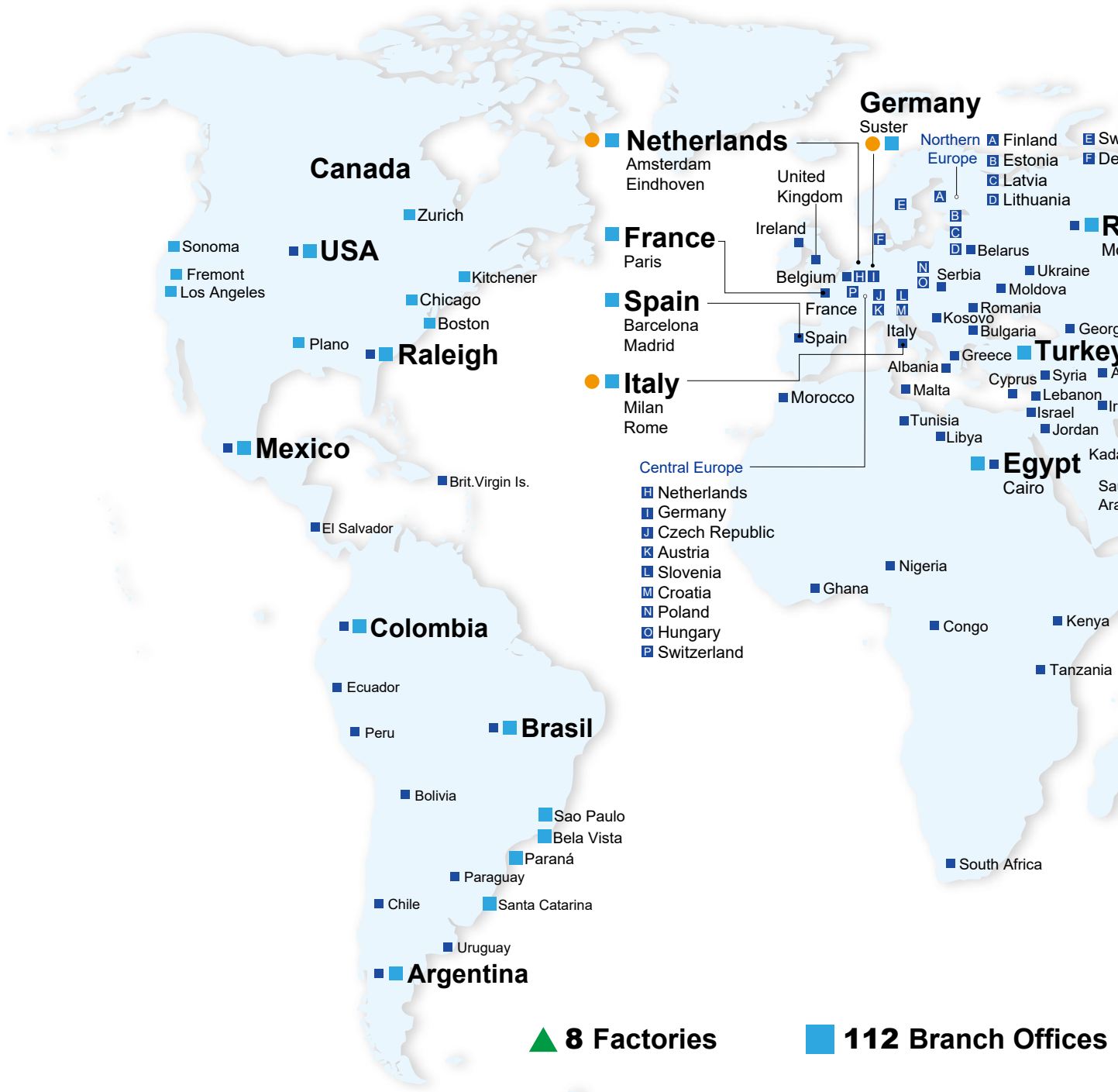

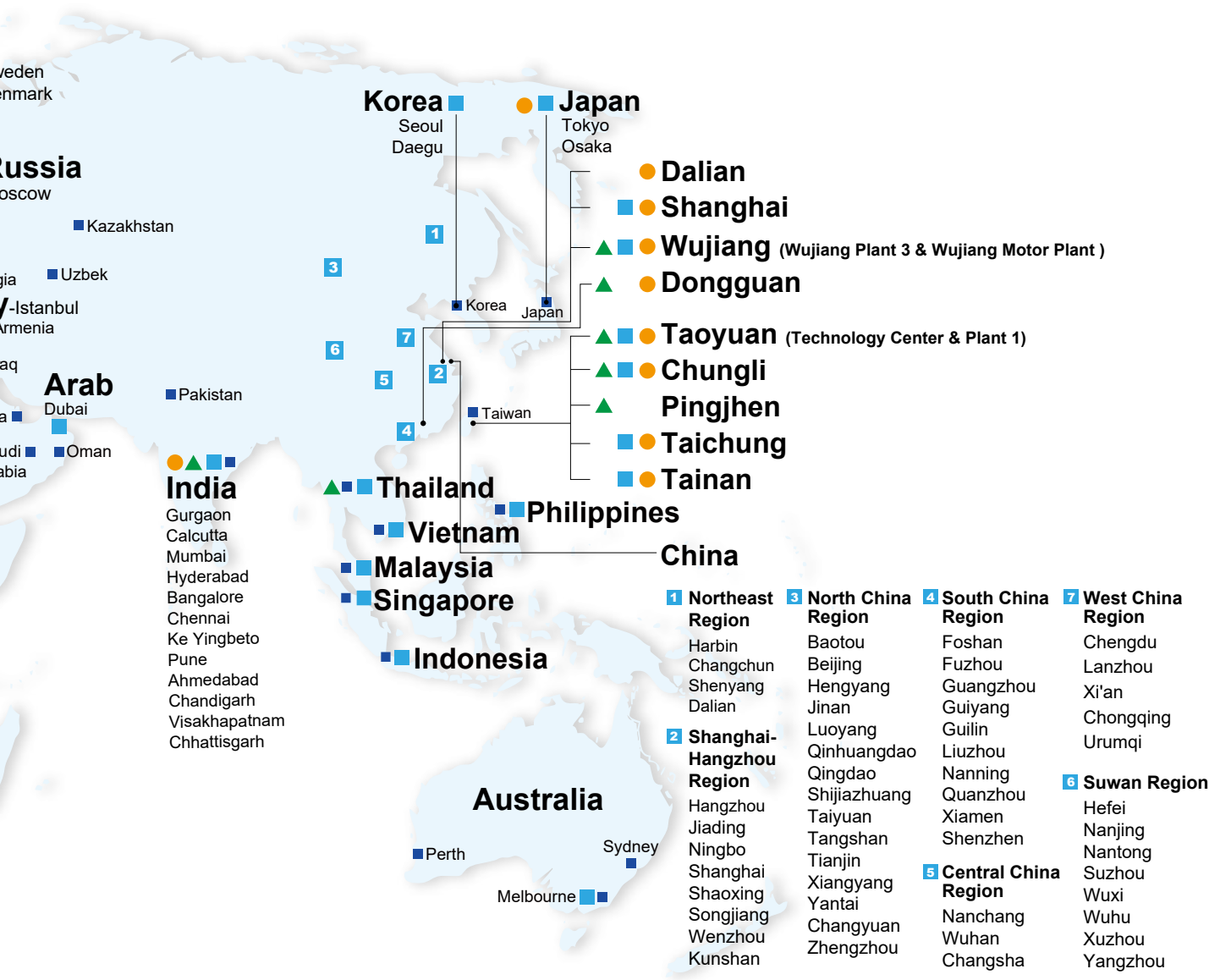

● 13 R&D Centers

■ 909 Distributors



Smarter. Greener. Together.

Industrial Automation Headquarters

Taiwan: Delta Electronics, Inc.

Taoyuan Technology Center
No.18, Xinglong Rd., Taoyuan District,
Taoyuan City 33068, Taiwan
TEL: +886-3-362-6301 / FAX: +886-3-371-6301

Asia

China: Delta Electronics (Shanghai) Co., Ltd.

No.182 Minyu Rd., Pudong Shanghai, P.R.C.
Post code : 201209
TEL: +86-21-6872-3988 / FAX: +86-21-6872-3996
Customer Service: 400-820-9595

Japan: Delta Electronics (Japan), Inc.

Industrial Automation Sales Department
2-1-14 Shibadaimon, Minato-ku
Tokyo, Japan 105-0012
TEL: +81-3-5733-1155 / FAX: +81-3-5733-1255

Korea: Delta Electronics (Korea), Inc.

1511, 219, Gasan Digital 1-Ro., Geumcheon-gu,
Seoul, 08501 South Korea
TEL: +82-2-515-5305 / FAX: +82-2-515-5302

Singapore: Delta Energy Systems (Singapore) Pte Ltd.

4 Kaki Bukit Avenue 1, #05-04, Singapore 417939
TEL: +65-6747-5155 / FAX: +65-6744-9228

India: Delta Electronics (India) Pvt. Ltd.

Plot No.43, Sector 35, HSIIDC Gurgaon,
PIN 122001, Haryana, India
TEL: +91-124-4874900 / FAX: +91-124-4874945

Thailand: Delta Electronics (Thailand) PCL.

909 Soi 9, Moo 4, Bangpoo Industrial Estate (E.P.Z),
Pattana 1 Rd., T.Phraksa, A.Muang,
Samutprakarn 10280, Thailand
TEL: +66-2709-2800 / FAX: +66-2709-2827

Australia: Delta Electronics (Australia) Pty Ltd.

Unit 20-21/45 Normanby Rd., Notting Hill Vic 3168, Australia
TEL: +61-3-9543-3720

Americas

USA: Delta Electronics (Americas) Ltd.

5101 Davis Drive, Research Triangle Park, NC 27709, U.S.A.
TEL: +1-919-767-3813 / FAX: +1-919-767-3969

Brazil: Delta Electronics Brazil

Rua Itapeva, 26 - 3º, andar Edifício Itapeva,
One - Bela Vista 01332-000 - São Paulo - SP - Brazil
TEL: +55-12-3932-2300 / FAX: +55-12-3932-237

Mexico: Delta Electronics International Mexico S.A. de C.V.

Gustavo Baz No. 309 Edificio E PB 103
Colonia La Loma, CP 54060
Tlalnepantla, Estado de México
TEL: +52-55-3603-9200

EMEA

EMEA Headquarters: Delta Electronics (Netherlands) B.V.

Sales: Sales.IA.EMEA@deltaww.com
Marketing: Marketing.IA.EMEA@deltaww.com
Technical Support: iatechnicalsupport@deltaww.com
Customer Support: Customer-Support@deltaww.com
Service: Service.IA.emea@deltaww.com
TEL: +31(0)40 800 3900

BENELUX: Delta Electronics (Netherlands) B.V.

Automotive Campus 260, 5708 JZ Helmond, The Netherlands
Mail: Sales.IA.Benelux@deltaww.com
TEL: +31(0)40 800 3900

DACH: Delta Electronics (Netherlands) B.V.

Coesterweg 45, D-59494 Soest, Germany
Mail: Sales.IA.DACH@deltaww.com
TEL: +49(0)2921 987 0

France: Delta Electronics (France) S.A.

ZI du bois Challand 2, 15 rue des Pyrénées,
Lisses, 91090 Evry Cedex, France
Mail: Sales.IA.FR@deltaww.com
TEL: +33(0)1 69 77 82 60

Iberia: Delta Electronics Solutions (Spain) S.L.U

Ctra. De Villaverde a Vallecas, 265 1º Dcha Ed.
Hormigueras – P.I. de Vallecas 28031 Madrid
TEL: +34(0)91 223 74 20

Carrer Llacuna 166, 08018 Barcelona, Spain

Mail: Sales.IA.Iberia@deltaww.com

Italy: Delta Electronics (Italy) S.r.l.

Via Meda 2-22060 Novedrate(CO)
Piazza Grazioli 18 00186 Roma Italy
Mail: Sales.IA.Italy@deltaww.com
TEL: +39 039 8900365

Russia: Delta Energy System LLC

Vereyskaya Plaza II, office 112 Vereyskaya str.
17 121357 Moscow Russia
Mail: Sales.IA.RU@deltaww.com
TEL: +7 495 644 3240

Turkey: Delta Greentech Elektronik San. Ltd. Sti. (Turkey)

Şerifali Mah. Hendem Cad. Kule Sok. No:16-A
34775 Ümraniye – İstanbul
Mail: Sales.IA.Turkey@deltaww.com
TEL: + 90 216 499 9910

MEA: Eltek Dubai (Eltek MEA DMCC)

OFFICE 2504, 25th Floor, Saba Tower 1,
Jumeirah Lakes Towers, Dubai, UAE
Mail: Sales.IA.MEA@deltaww.com
TEL: +971(0)4 2690148